

PERFORMANCE
MADE
SMARTER

Product manual

5114

Programmable transmitter

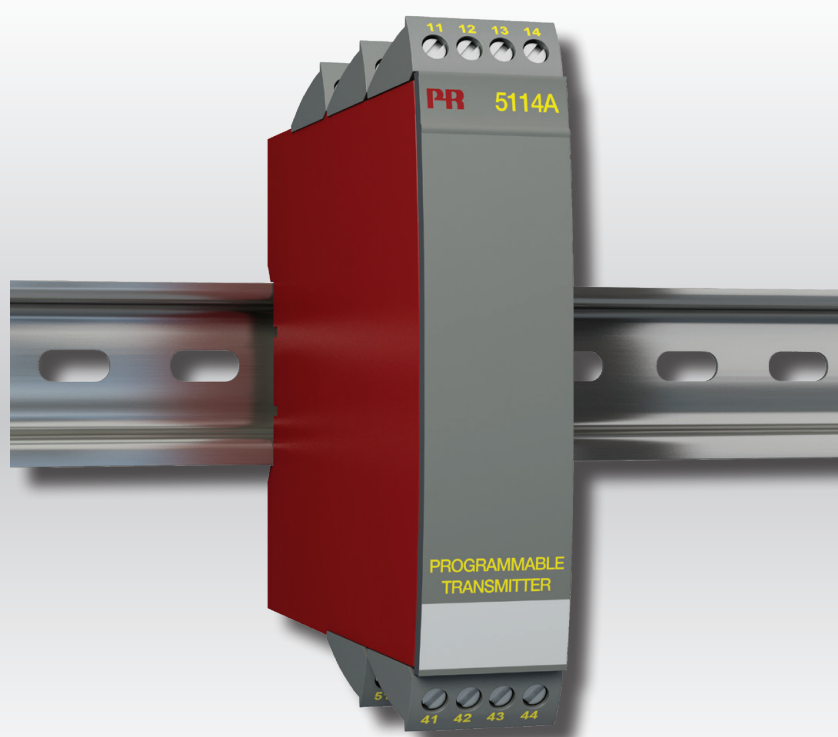

TEMPERATURE | I.S. INTERFACES | COMMUNICATION INTERFACES | MULTIFUNCTIONAL | ISOLATION | DISPLAY

No. 5114V110-UK
From serial no. 251849041

PR
electronics

6 Product Pillars

to meet your every need

Individually outstanding, unrivalled in combination

With our innovative, patented technologies, we make signal conditioning smarter and simpler. Our portfolio is composed of six product areas, where we offer a wide range of analog and digital devices covering over a thousand applications in industrial and factory automation. All our products comply with or surpass the highest industry standards, ensuring reliability in even the harshest of environments and have a 5-year warranty for greater peace of mind.



Our range of temperature transmitters and sensors provides the highest level of signal integrity from the measurement point to your control system. You can convert industrial process temperature signals to analog, bus or digital communications using a highly reliable point-to-point solution with a fast response time, automatic self-calibration, sensor error detection, low drift, and top EMC performance in any environment.



We deliver the safest signals by validating our products against the toughest safety standards. Through our commitment to innovation, we have made pioneering achievements in developing I.S. interfaces with SIL 2 Full Assessment that are both efficient and cost-effective. Our comprehensive range of analog and digital intrinsically safe isolation barriers offers multifunctional inputs and outputs, making PR an easy-to-implement site standard. Our backplanes further simplify large installations and provide seamless integration to standard DCS systems.



We provide inexpensive, easy-to-use, future-ready communication interfaces that can access your PR installed base of products. All the interfaces are detachable, have a built-in display for readout of process values and diagnostics, and can be configured via push-buttons. Product specific functionality includes communication via Modbus and Bluetooth and remote access using our PR Process Supervisor (PPS) application, available for iOS and Android.



Our unique range of single devices covering multiple applications is easily deployable as your site standard. Having one variant that applies to a broad range of applications can reduce your installation time and training, and greatly simplify spare parts management at your facilities. Our devices are designed for long-term signal accuracy, low power consumption, immunity to electrical noise and simple programming.



Our compact, fast, high-quality 6 mm isolators are based on microprocessor technology to provide exceptional performance and EMC-immunity for dedicated applications at a very low total cost of ownership. They can be stacked both vertically and horizontally with no air gap separation between units required.



Our display range is characterized by its flexibility and stability. The devices meet nearly every demand for display readout of process signals and have universal input and power supply capabilities. They provide a real-time measurement of your process value no matter the industry and are engineered to provide a user-friendly and reliable relay of information, even in demanding environments.

Programmable transmitter

5114

Table of contents

Warning	4
Symbol identification	4
Safety instructions	5
How to demount system 5000	6
Application	7
Technical characteristics	7
Input types	7
Output	8
Configuration	8
Order	8
Electrical specifications	8
5114 connection to Loop Link	12
Selection of input type	12
Connections	13
Block diagram	15
Document history	16

Warning



GENERAL

This device is designed for connection to hazardous electric voltages. Ignoring this warning can result in severe personal injury or mechanical damage. To avoid the risk of electric shock and fire, the safety instructions of this manual must be observed and the guidelines followed. The specifications must not be exceeded, and the device must only be applied as described in the following. Prior to the commissioning of the device, this manual must be examined carefully. Only qualified personnel (technicians) should install this device. If the equipment is used in a manner not specified by the manufacturer, the protection provided by the equipment may be impaired.

Warning



**HAZARD-
OUS
VOLTAGE**

Until the device is fixed, do not connect hazardous voltages to the device. The following operations should only be carried out on a disconnected device and under ESD-safe conditions:

- Dismantlement of the device for setting of DIP-switches and jumpers.
- General mounting, wire connection and disconnection.
- Troubleshooting the device.

Repair of the device and replacement of circuit breakers must be done by PR electronics A/S only.



Warning



**INSTAL-
LATION**

SYSTEM 5000 must be mounted on a DIN rail according to DIN 60715. The communication connector of SYSTEM 5000 is connected to the input terminals on which dangerous voltages can occur, and it must only be connected to the programming unit Loop Link by way of the enclosed cable.

Symbol identification



Triangle with an exclamation mark: Read the manual before installation and commissioning of the device in order to avoid incidents that could lead to personal injury or mechanical damage. Warning / demand. Potentially lethal situations.



The CE mark proves the compliance of the device with the essential requirements of the directives.



The double insulation symbol shows that the device is protected by double or reinforced insulation.

Safety instructions

Definitions

Hazardous voltages have been defined as the ranges: 75 to 1500 Volt DC, and 50 to 1000 Volt AC.

Technicians are qualified persons educated or trained to mount, operate, and also trouble-shoot technically correct and in accordance with safety regulations.

Operators, being familiar with the contents of this manual, adjust and operate the knobs or potentiometers during normal operation.

Receipt and unpacking

Unpack the device without damaging it and check whether the device type corresponds to the one ordered. The packing should always follow the device until this has been permanently mounted.

Environment

Avoid direct sun light, dust, high temperatures, mechanical vibrations and shock, and rain and heavy moisture. If necessary, heating in excess of the stated limits for ambient temperatures should be avoided by way of ventilation.

The device must be installed in pollution degree 2 or better.

The device is designed to be safe at least under an altitude up to 2 000 m.

The device is designed for indoor use.

Mounting

Only technicians, who are familiar with the technical terms, warnings, and instructions in the manual and who are able to follow these, should connect the device. Should there be any doubt as to the correct handling of the device, please contact your local distributor or, alternatively,

PR electronics A/S
www.prelectronics.com

Mounting and connection of the device should comply with national legislation for mounting of electric materials, i.e. wire cross section, protective fuse, and location.

Stranded wire should be installed with an insulation stripping length of 5 mm or via a suitable insulated terminal such as a bootlace ferrule.

Descriptions of input / output and supply connections are shown in the block diagram and side label.

The following apply to fixed hazardous voltages-connected devices:

The max. size of the protective fuse is 10 A and, together with a power switch, it should be easily accessible and close to the device. The power switch should be marked with a label telling it will switch off the voltage to the device.

Year of manufacture can be taken from the first two digits in the serial number.

Calibration and adjustment

During calibration and adjustment, the measuring and connection of external voltages must be carried out according to the specifications of this manual. The technician must use tools and instruments that are safe to use.

Normal operation

Operators are only allowed to adjust and operate devices that are safely fixed in panels, etc., thus avoiding the danger of personal injury and damage. This means there is no electrical shock hazard, and the device is easily accessible.

Cleaning

When disconnected, the device may be cleaned with a cloth moistened with distilled water.

Liability

To the extent the instructions in this manual are not strictly observed, the customer cannot advance a demand against PR electronics A/S that would otherwise exist according to the concluded sales agreement.

How to demount system 5000

First, remember to demount the connectors with hazardous voltages.

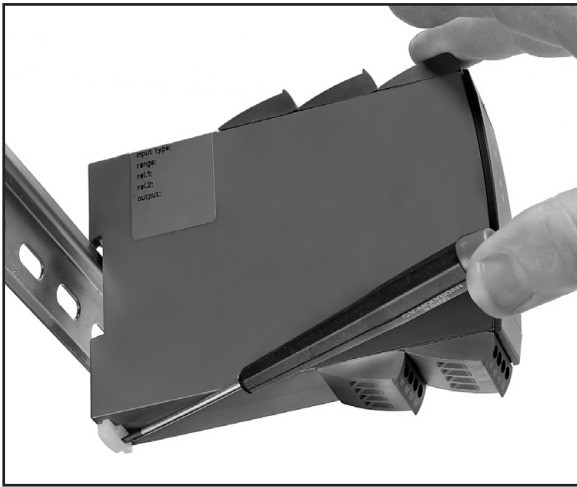

Picture 1:
By lifting the bottom lock, the device is detached from the DIN rail.

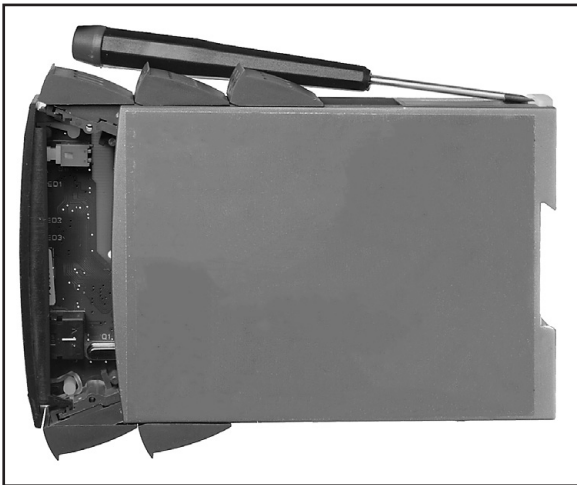

Picture 2:
By lifting the upper lock and pulling the front plate simultaneously the PCB can be removed. Switches and jumpers can now be adjusted.

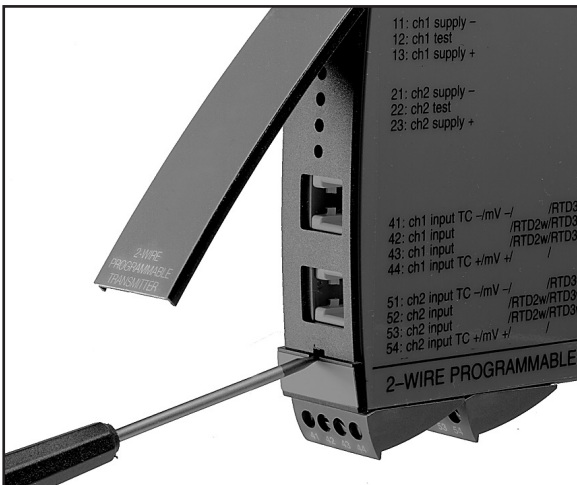

Picture 3:
Access to programming connector

Programmable transmitter 5114

- Input for RTD, TC, mV, linear resistance, mA, and V
- 3-port 3.75 kVAC galvanic isolation
- Current and voltage output
- Universal voltage supply
- 1- and 2-channel versions
- Loop supply > 17.1 V

Application

Electronic temperature measurement with resistance sensor or thermocouple sensor. • Power supply for 2-wire transmitters. • Amplification of mV signals. • Conversion of linear resistance variation. • Galvanic isolation of analog signals. • Measurement of floating signals. • Linearisation of non-linear Ohm, mV, mA, or voltage signals. • Separation of circuits in PELV/SELV installations. • The transmitter is especially suitable for emitting the output current signal, either as a standard current signal or as a loop signal.

Technical characteristics

The unit is based on a microprocessor core with an efficient program operation. The basic calibration data and present set-up are stored in an EEPROM thereby avoiding the loss or change of data at power off. The 2-channel version has a full galvanic isolation between the channels. By way of jumpers on the PCB the input in the standard version can be programmed either for a temperature or a current / voltage input. This means that one channel can work as for instance a temperature transmitter and the other can work as an isolation amplifier. Measurement range, signal parameters, and output span are configured to the present task by way of a PC and PR electronics A/S' communications interface Loop Link.

Input types

Temperature input - jumpers in position 1

Thermocouple input (TC) for standard thermocouples type B, E, J, K, L, N, R, S, T, U, W3, W5, LR according to the norms IEC 584, DIN 43710, ASTM E988-90 and GOST 3044-84. The CJC can be selected in 3 different ways: internally in the terminal, externally by way of a Pt100 / Ni100 sensor, or externally with a constant temperature.

If internal compensation is selected, a terminal with a built-in temperature sensor must be ordered separately (PR type no. 5910 and 5913). Sensor error detection is available.

RTD input for Pt100...Pt1000 according to the norm IEC 751 and Ni100...Ni1000 according to the norm DIN 43760.

Automatic cable compensation at a 3- or 4-wire connection. At a 2-wire connection the cable resistance can be entered or measured by the configuration program and sent to the device which then compensates by the entered cable resistance. Sensor error detection is available.

Resistance input for resistance measurement with cable compensation as described under the RTD input. Sensor error detection is available.

The **mV input** is programmable in the range -150...+150 mV.

Current / voltage input - jumpers in position 2

The **current input** is programmable in the range 0...100 mA, for instance 4...20 mA.

The **voltage input** is programmable in the range 0...250 VDC.

Auxiliary supplies are selected in the configuration program:

Loop transmitter supply > 17.1 VDC.

Reference voltage of 2.5 VDC, for instance as a supply for potentiometers.

Output

The **analog standard current / voltage output** is programmable in the range 0...20 mA, for instance 4...20 mA and 0...10 VDC. The output voltage can be ordered for a maximum of 12 VDC by a special shunt resistance. The output signal is proportional and linear to the value of the input signal. Special set-ups can be selected in the configuration program, for instance a customised linearisation, a reversed output, a limiter according to the selected output span, and selection of an output value in case of a sensor error. Maximum load on the current output is 600 Ω . Minimum load on the voltage output is 500 k Ω .

Loop 4...20 mA current output

By wiring the current signal alternatively, the output works as a loop output. If the supply voltage for the 5114 disappears, the output current drops to < 4 mA.

Sensor error detection

The output can be set up at an RTD, thermocouple and linear resistance input to go to max., to min. or entered value at sensor error detection. If the output is set to 4...20 mA it is also possible to select NAMUR NE43 Upscale or Downscale.

Configuration

The transmitter is configured to the present task by way of a PC and PR electronics A/S' communications interface Loop Link. The communications interface is galvanically isolated to protect the PC port. Communication is 2-way to allow the retrieval of the transmitter set-up into the PC and to allow the transmission of the PC set-up to the transmitter. For users who do not wish to do the set-up themselves, the 5114 can be delivered configured according to customer specifications: input type, measurement range, sensor error detection, and output signal.

Order

Type	Channels
5114A	Single : A
	Double : B

Example: 5114AB

NB! For TC inputs with internal CJC, remember to order the CJC connectors type 5910 (ch. 1) and 5913 (ch. 2).

Electrical specifications

Environmental conditions

Operating temperature	-20°C to +60°C
Calibration temperature	20...28°C
Relative humidity	< 95% RH (non-cond.)
Protection degree	IP20

Mechanical specifications

Dimensions (HxWxD)	109 x 23.5 x 130 mm
DIN rail type.	DIN EN 60715 - 35 mm
Weight	225 g
Wire size (min...max.)	0.13...2.08 mm ² AWG 26...14 stranded wire
Screw terminal torque.	0.5 Nm
Vibration.	IEC 60068-2-6
2...13.2 Hz	±1 mm
13.2...100 Hz.	±0.7 g

Common specifications

Supply voltage, universal.	21.6...253 VAC, 50...60 Hz or 19.2...300 VDC
Fuse	400 mA SB / 250 VAC
Max. required power, 1 / 2 channels	2.1 W / 2.8 W
Max. power dissipation	2.0 W
<i>Max. required power is the maximum power needed at terminals 31 and 33.</i>	
<i>Max. power dissipation is the maximum power dissipated by the device.</i>	
Isolation voltage, test / operation.	3.75 kVAC / 250 VAC
PELV/SELV.	IEC 61140
Programming	Loop Link

Signal / noise ratio Min. 60 dB (0...100 kHz)
 Updating time:
 Temperature input 115 ms
 mA / V / mV input 75 ms
 Response time (0...90%, 100...10%), programmable:
 Temperature input 400 ms...60 s
 mA / V / mV input 250 ms...60 s
 Signal dynamics, input 22 bit
 Signal dynamics, output 16 bit

Accuracy, the greater of the general and basic values:

General values		
Input type	Absolute accuracy	Temperature coefficient
All	$\leq \pm 0.05\%$ of span	$\leq \pm 0.01\%$ of span / °C

Basic values		
Input type	Basic accuracy	Temperature coefficient
mA	$\leq \pm 4 \mu\text{A}$	$\leq \pm 0.4 \mu\text{A} / ^\circ\text{C}$
Volt	$\leq \pm 10 \mu\text{V}$	$\leq \pm 1 \mu\text{V} / ^\circ\text{C}$
RTD	$\leq \pm 0.2^\circ\text{C}$	$\leq \pm 0.01^\circ\text{C} / ^\circ\text{C}$
Lin. R	$\leq \pm 0.1\Omega$	$\leq \pm 10 \text{m}\Omega / ^\circ\text{C}$
TC type: E, J, K, L, N, T, U	$\leq \pm 1^\circ\text{C}$	$\leq \pm 0.05^\circ\text{C} / ^\circ\text{C}$
TC type: B, R, S, W3, W5, LR	$\leq \pm 2^\circ\text{C}$	$\leq \pm 0.2^\circ\text{C} / ^\circ\text{C}$

EMC - immunity influence.	$< \pm 0.5\%$ of span
Extended EMC immunity: NAMUR NE 21, A criterion, burst	$< \pm 1\%$ of span

Auxiliary supplies:

Reference voltage 2.5 VDC $\pm 0.5\%$ / 15 mA
 2-wire supply (pin 44...42 and 54...52). 28...17.1 VDC / 0...20 mA

Electrical specifications, temperature input

TC input

Type	Min. value	Max. value	Min. span	Standard
B	+400°C	+1820°C	200°C	IEC 60584-1
E	-100°C	+1000°C	50°C	IEC 60584-1
J	-100°C	+1200°C	50°C	IEC 60584-1
K	-180°C	+1372°C	50°C	IEC 60584-1
L	-100°C	+900°C	50°C	DIN 43710
N	-180°C	+1300°C	100°C	IEC 60584-1
R	-50°C	+1760°C	200°C	IEC 60584-1
S	-50°C	+1760°C	200°C	IEC 60584-1
T	-200°C	+400°C	50°C	IEC 60584-1
U	-200°C	+600°C	75°C	DIN 43710
W3	0°C	+2300°C	200°C	ASTM E988-90
W5	0°C	+2300°C	200°C	ASTM E988-90
LR	-200°C	+800°C	50°C	GOST 3044-84

Max. offset 50% of selec. max. value
 Sensor error current Nom. 30 μ A
 CJC $\leq \pm 1^\circ\text{C}$
 Sensor error detection Yes

mV input

Measurement range -150...+150 mV
 Min. measurement range 5 mV
 Max. offset 50% of selec. max. value
 Input resistance Nom. 10 M Ω

RTD and linear resistance input

Input type	Min. value	Max. value	Min. span	Standard
Pt100	-200 $^\circ\text{C}$	+850 $^\circ\text{C}$	25 $^\circ\text{C}$	IEC 60751
Ni100	-60 $^\circ\text{C}$	+250 $^\circ\text{C}$	25 $^\circ\text{C}$	DIN 43760
Linear resist.	0 Ω	5000 Ω	30 Ω	-

Max. offset 50% of selec. max. value
 Max. cable resistance per wire 10 Ω
 Sensor current Nom. 0.2 mA
 Effect of sensor cable resistance, (3- / 4-wire) < 0.002 Ω / Ω
 Sensor error detection Yes

Electrical specifications, mA / V / mV input

Current input

Measurement range 0...100 mA
 Min. measurement range (span) 4 mA
 Max. offset 50% of selec. max. value
 Input resistance:
 Supplied unit nom. 10 Ω + PTC 10 Ω
 Non-supplied unit $R_{\text{SHUNT}} = \infty$, $V_{\text{DROP}} < 6$ V

Voltage input

Measurement range 0...250 VDC
 Min. measurement range (span) 5 mVDC
 Max. offset 50% of selec. max. value
 Input resistance ≤ 2.5 VDC Nom. 10 M Ω
 > 2.5 VDC Nom. 5 M Ω

Electrical specifications - OUTPUT

Current output

Signal range (span) 0...20 mA
 Min. signal range (span) 10 mA
 Max. offset 50% of selec. max. value
 Load $\leq 600 \Omega$
 Load stability $\leq 0.01\%$ of span / 100 Ω
 Current limit. ≤ 28 mA

Voltage output

Signal range (span) 0...10 VDC
 Min. signal range (span) 500 mV
 Max. offset 50% of selec. max. value
 Load ≥ 500 k Ω

2-wire 4...20 mA output

Signal range. 4...20 mA
 Load stability $\leq 0.01\%$ of span / 100 Ω
 Load resistance. $\leq (V_{\text{supply}}-3.5) / 0.023$ A [Ω]
 Max. external 2-wire supply 29 VDC
 Effect of external 2-wire supply voltage change < 0.005% of span / V

Sensor error detection

Programmable	0...23 mA
NAMUR NE43 Upscale	23 mA
NAMUR NE43 Downscale.	3.5 mA
No function	Not defined

Of span = Of the presently selected range

Observed authority requirements

EMC.	2014/30/EU
LVD	2014/35/EU
RoHS	2011/65/EU
EAC	TR-CU 020/2011
EAC LVD	TR-CU 004/2011

Approvals

Det Norske Veritas, Ships & Offshore.	TAA0000101
---	------------

5114 connection to Loop Link

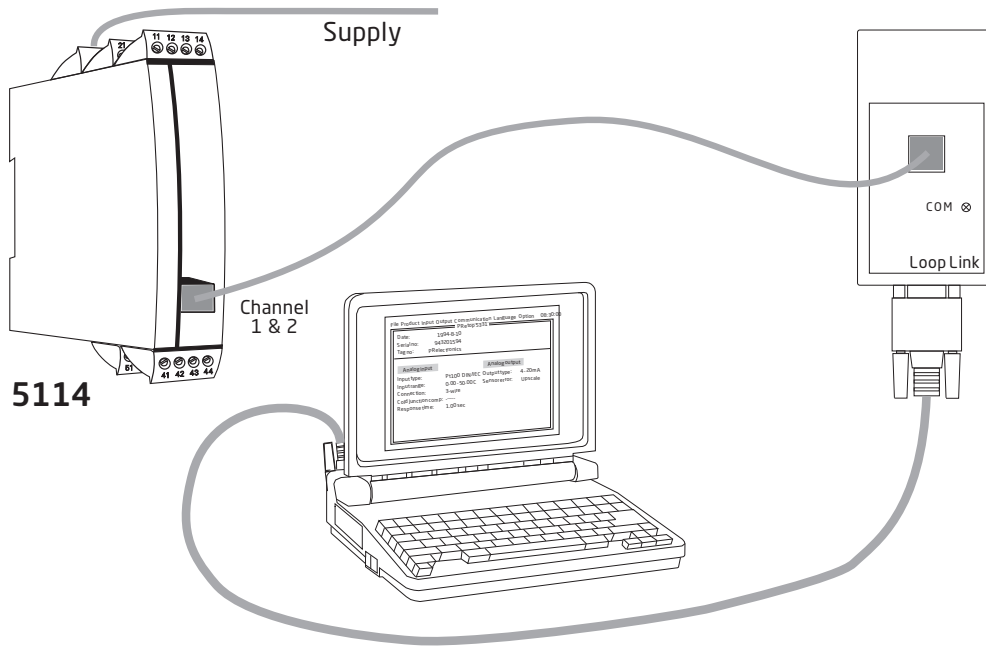

Selection of input type

Input	JP 1	JP 2	JP 3	JP 4
Temperature channel 1	1	1	-	-
Temperature channel 2	-	-	1	1
Current / voltage channel 1	2	2	-	-
Current / voltage channel 2	-	-	2	2

Connections

Supply:

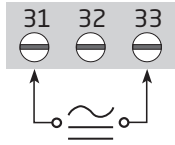

Inputs:

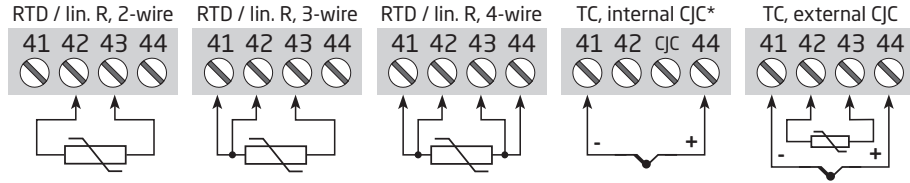

* If the device is reconfigured from temperature measurement with CJC connector to analog measurement, the CJC connector must be demounted. Order separately: 5910 CJC connector for channel 1.

Channel 1

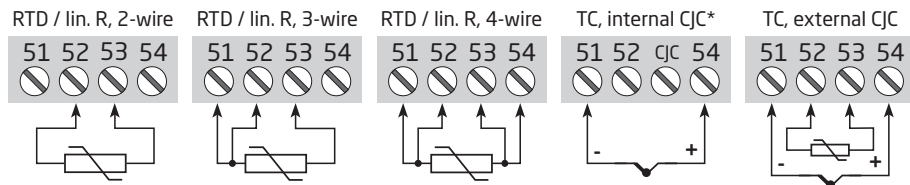
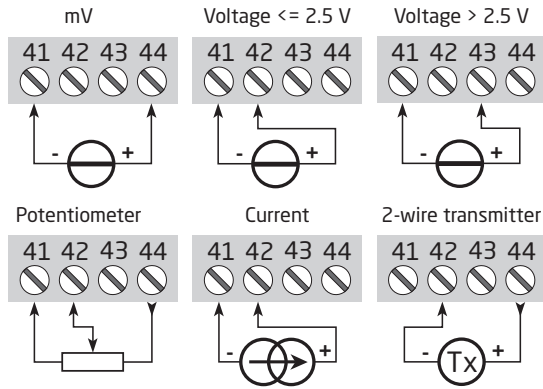

* If the device is reconfigured from temperature measurement with CJC connector to analog measurement, the CJC connector must be demounted. Order separately: 5913 CJC connector for channel 2.

Channel 2

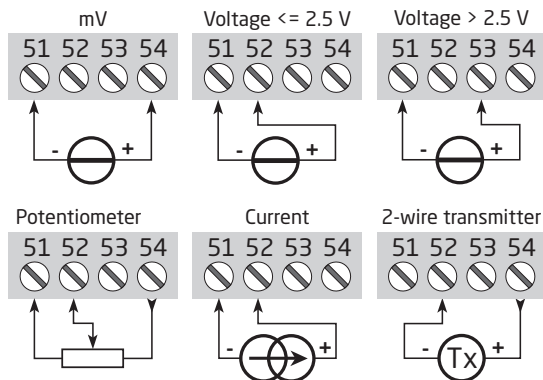

Connections

Outputs:

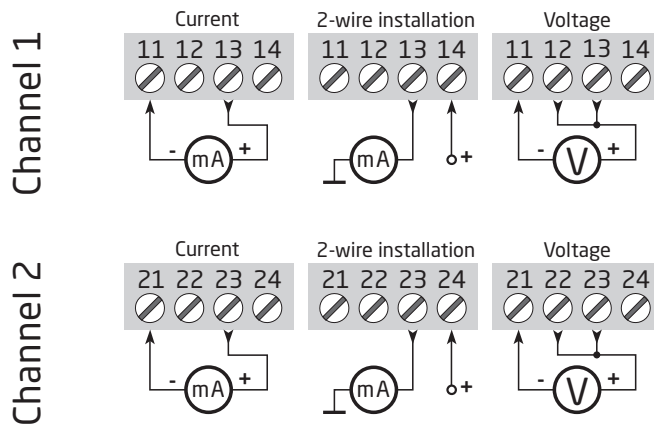

Block diagram

* Accessories: 5910 CJC connector CH1, 5913 CJC connector CH2.

Channel1 shown as a temperature input:

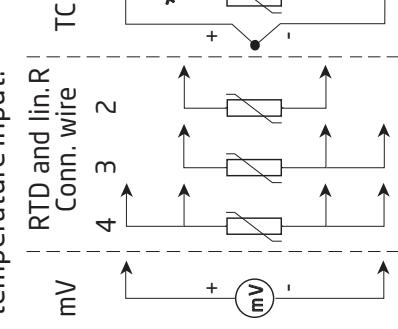

!! If channel 2, use terminal no. 54...51

Channel 2 shown as a current/voltage input:

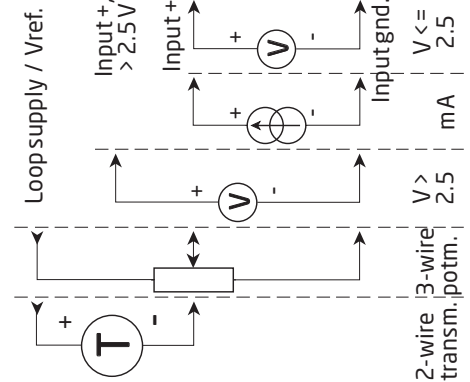

!! If channel 1, use terminal no. 44...41

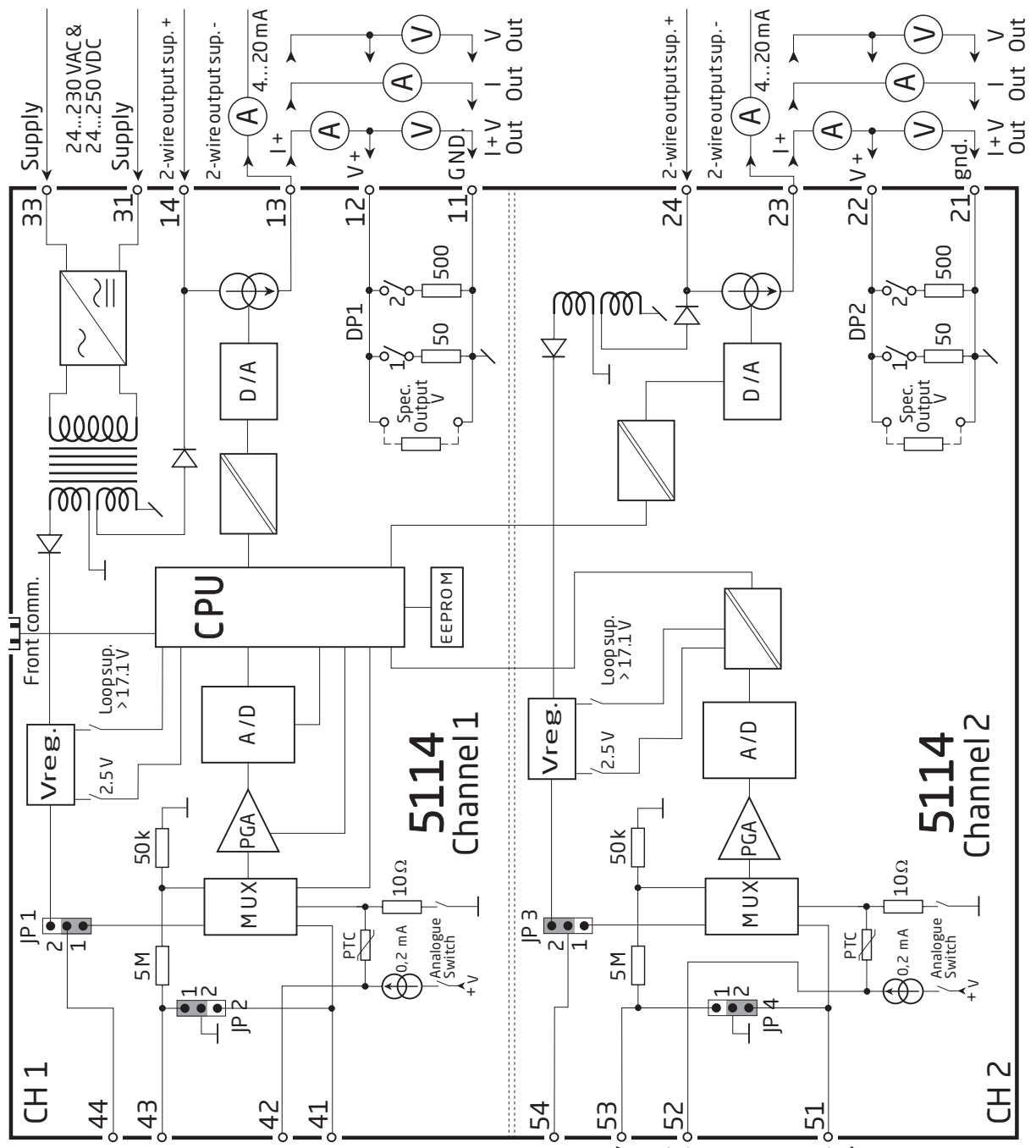

Document history

The following list provides notes concerning revisions of this document.

Rev. ID	Date	Notes
108	2208	Safety instructions updated acc. to LVD.
109	2443	New EAC Ex certificate.
110	2540	Model 5114B discontinued.

We are near you, *all over the world*

Our trusted red boxes are supported wherever you are

All our devices are backed by expert service and a 5-year warranty. With each product you purchase, you receive personal technical support and guidance, day-to-day delivery, repair without charge within the warranty period and easily accessible documentation.

We are headquartered in Denmark, and have offices and authorized partners the world over. We are a local

business with a global reach. This means that we are always nearby and know your local markets well. We are committed to your satisfaction and provide **PERFORMANCE MADE SMARTER** all around the world.

For more information on our warranty program, or to meet with a sales representative in your region, visit prelectronics.com.

Benefit today from *PERFORMANCE MADE SMARTER*

PR electronics is the leading technology company specialized in making industrial process control safer, more reliable and more efficient. Since 1974, we have been dedicated to perfecting our core competence of innovating high precision technology with low power consumption. This dedication continues to set new standards for products communicating, monitoring and connecting our customers' process measurement points to their process control systems.

Our innovative, patented technologies are derived from our extensive R&D facilities and from having a great understanding of our customers' needs and processes. We are guided by principles of simplicity, focus, courage and excellence, enabling some of the world's greatest companies to achieve PERFORMANCE MADE SMARTER.