

PERFORMANCE
MADE
SMARTER

Product manual

5203B-U9

Ex solenoid / alarm driver

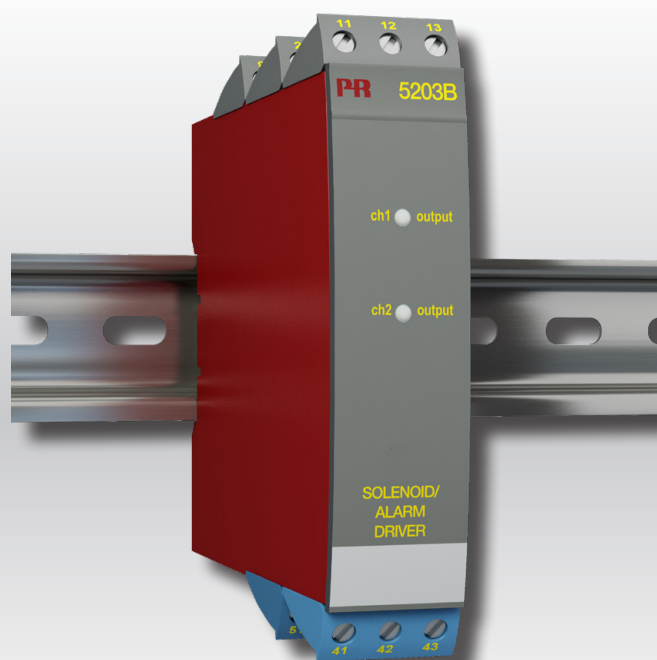

TEMPERATURE | I.S. INTERFACES | COMMUNICATION INTERFACES | MULTIFUNCTIONAL | ISOLATION | DISPLAY

No. 5203B-U9V107-UK

From serial no.: 5203BF1-U9: 241537041

5203BH1-U9: 221521025 / 5203BH2-U9: 251368094

5203BI1-U9: 221521030 / 5203BI2-U9: 251368048

PR
electronics

6 Product Pillars

to meet your every need

Individually outstanding, unrivalled in combination

With our innovative, patented technologies, we make signal conditioning smarter and simpler. Our portfolio is composed of six product areas, where we offer a wide range of analog and digital devices covering over a thousand applications in industrial and factory automation. All our products comply with or surpass the highest industry standards, ensuring reliability in even the harshest of environments and have a 5-year warranty for greater peace of mind.



Temperature

Our range of temperature transmitters and sensors provides the highest level of signal integrity from the measurement point to your control system. You can convert industrial process temperature signals to analog, bus or digital communications using a highly reliable point-to-point solution with a fast response time, automatic self-calibration, sensor error detection, low drift, and top EMC performance in any environment.



I.S. Interface

We deliver the safest signals by validating our products against the toughest safety standards. Through our commitment to innovation, we have made pioneering achievements in developing I.S. interfaces with SIL 2 Full Assessment that are both efficient and cost-effective. Our comprehensive range of analog and digital intrinsically safe isolation barriers offers multifunctional inputs and outputs, making PR an easy-to-implement site standard. Our backplanes further simplify large installations and provide seamless integration to standard DCS systems.



Communication

We provide inexpensive, easy-to-use, future-ready communication interfaces that can access your PR installed base of products. All the interfaces are detachable, have a built-in display for readout of process values and diagnostics, and can be configured via push-buttons. Product specific functionality includes communication via Modbus and Bluetooth and remote access using our PR Process Supervisor (PPS) application, available for iOS and Android.



Multifunction

Our unique range of single devices covering multiple applications is easily deployable as your site standard. Having one variant that applies to a broad range of applications can reduce your installation time and training, and greatly simplify spare parts management at your facilities. Our devices are designed for long-term signal accuracy, low power consumption, immunity to electrical noise and simple programming.



Isolation

Our compact, fast, high-quality 6 mm isolators are based on microprocessor technology to provide exceptional performance and EMC-immunity for dedicated applications at a very low total cost of ownership. They can be stacked both vertically and horizontally with no air gap separation between units required.



Display

Our display range is characterized by its flexibility and stability. The devices meet nearly every demand for display readout of process signals, and have universal input and power supply capabilities. They provide a real-time measurement of your process value no matter the industry, and are engineered to provide a user-friendly and reliable relay of information, even in demanding environments.

Ex solenoid / alarm driver 5203B-U9

Contents

Warning	2
Symbol identification	2
Safety instructions	3
How to demount system 5000	4
Applications	5
Technical characteristics	5
Mounting / installation	5
Applications	6
Order	7
Electrical specifications	7
DIP switch programming	8
Block diagram	9
Connections	10
UL Control Drawing	11
Document history	12

Warning



GENERAL

This device is designed for connection to hazardous electric voltages. Ignoring this warning can result in severe personal injury or mechanical damage.

To avoid the risk of electric shock and fire, the safety instructions of this manual must be observed and the guidelines followed.

The specifications must not be exceeded, and the device must only be applied as described in the following.

Prior to the commissioning of the device, this manual must be examined carefully.

Only qualified personnel (technicians) should install this device.

If the equipment is used in a manner not specified by the manufacturer, the protection provided by the equipment may be impaired.

Warning



**HAZARD-
OUS
VOLTAGE**

Until the device is fixed, do not connect hazardous voltages to the device. The following operations should only be carried out on a disconnected device and under ESD-safe conditions:

Dismantlement of the device for setting of DIP-switches and jumpers.

General mounting, connection and disconnection of wires.

Troubleshooting the device.

Repair of the device replacement of circuit breakers must be done by PR electronics A/S only.

Warning



**INSTAL-
LATION**

To keep the safety distances, one relay must not be connected to hazardous voltage at the same time as the other relay on the same channel is connected to non-hazardous voltage.

Symbol identification



Triangle with an exclamation mark: Warning / demand. Potentially lethal situations.



The CE mark proves the compliance of the device with the essential requirements of the directives.



The **double insulation symbol** shows that the device is protected by double or reinforced insulation.

Safety instructions

Definitions

Hazardous voltages have been defined as the ranges: 75 to 1500 Volt DC, and 50 to 1000 Volt AC.

Technicians are qualified persons educated or trained to mount, operate, and also trouble-shoot technically correct and in accordance with safety regulations.

Operators, being familiar with the contents of this manual, adjust and operate the knobs or potentiometers during normal operation.

Receipt and unpacking

Unpack the device without damaging it and check whether the device type corresponds to the one ordered. The packing should always follow the device until this has been permanently mounted.

Environment

Avoid direct sun light, dust, high temperatures, mechanical vibrations and shock, and rain and heavy moisture. If necessary, heating in excess of the stated limits for ambient temperatures should be avoided by way of ventilation.

The device must be installed in pollution degree 2 or better.

The device is designed to be safe at least under an altitude up to 2 000 m.

The device is designed for indoor use.

Mounting

Only technicians, who are familiar with the technical terms, warnings, and instructions in the manual and who are able to follow these, should connect the device. Should there be any doubt as to the correct handling of the device, please contact your local distributor or, alternatively,

PR electronics A/S
www.prelectronics.com

Mounting and connection of the device should comply with national legislation for mounting of electric materials, i.e. wire cross section, protective fuse, and location.

Stranded wire should be installed with an insulation stripping length of 5 mm or via a suitable insulated terminal such as a bootlace ferrule.

Descriptions of input / output and supply connections are shown in the block diagram and on the side label.

The following apply to fixed hazardous voltages-connected devices:

The max. size of the protective fuse is 10 A and, together with a power switch, it should be easily accessible and close to the device. The power switch should be marked with a label indicating that it will switch off the voltage to the device.

Year of manufacture can be taken from the first two digits in the serial number.

Calibration and adjustment

During calibration and adjustment, the measuring and connection of external voltages must be carried out according to the specifications of this manual. The technician must use tools and instruments that are safe to use.

Normal operation

Operators are only allowed to adjust and operate devices that are safely fixed in panels, etc., thus avoiding the danger of personal injury and damage. This means there is no electrical shock hazard, and the device is easily accessible.

Cleaning

When disconnected, the device may be cleaned with a cloth moistened with distilled water.

Liability

To the extent the instructions in this manual are not strictly observed, the customer cannot advance a demand against PR electronics A/S that would otherwise exist according to the concluded sales agreement.

How to demount system 5000

First, remember to demount the connectors with hazardous voltages.

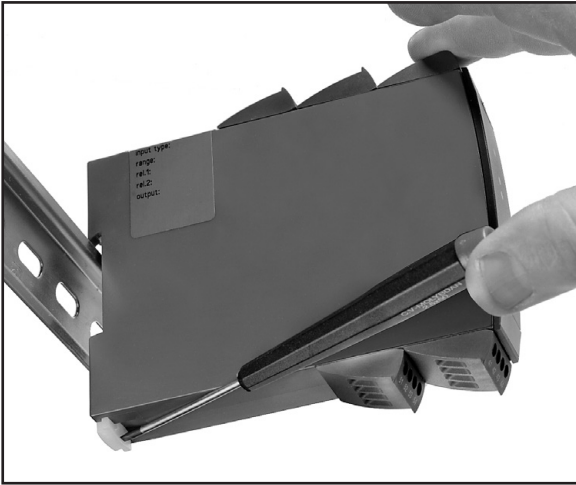

Picture 1:

The device is detached from the DIN rail by moving the bottom lock down.

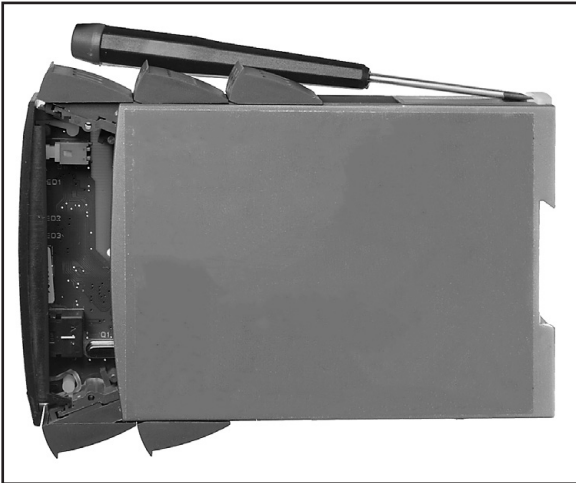

Picture 2:

Then, by lifting the upper lock and pulling the front plate simultaneously, the PCB is removed. Switches and jumpers can now be adjusted.

Ex solenoid / alarm driver 5203B-U9

- UL 913-approved version for US market only
- 1- or 2-channel version
- Solenoid driver for I.S. area
- 3- / 5-port 3.75 kVAC galvanic isolation
- Digitally controlled voltage supply for I.S. area
- Universal supply by AC or DC

Applications

- Driver with safety barrier for the control of ON / OFF solenoids mounted in hazardous area.
- Driver with safety barrier for the supply of LEDs and acoustic alarms mounted in hazardous area.
- Voltage supply with ON / OFF control of other equipment.

Technical characteristics

- PR5203B-U9 has a digital input per channel for the control of the I.S. output voltage.
- Supply, inputs, and outputs are floating and galvanically separated.

Mounting / installation

- Mounted vertically or horizontally on a DIN rail. By way of the 2-channel version up to 84 channels per meter can be mounted.

Applications

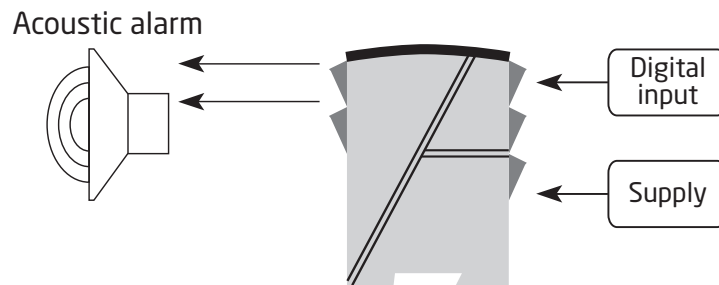
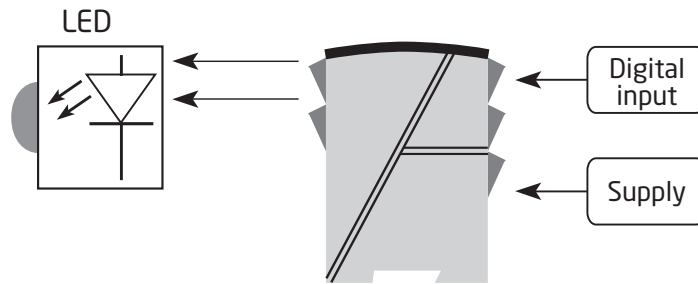
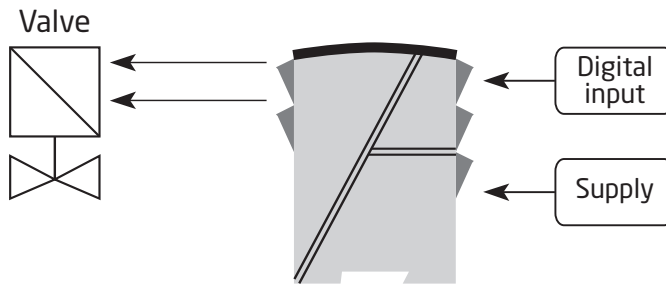

Order

Type	Input	I.S. barrier	Channels	I.S. approval						
5203B	PNP	:1	Type	: F	Single	: 1	UL913	:-U9		
	Switch	:2	Type	: H					Single	: 1
	NPN	:3	Type	: I					Double	: 2

Electrical specifications

Environmental conditions

Operating temperature	-20°C to +60°C
Calibration temperature	20...28°C
Relative humidity	< 95% RH (non-cond.)
Protection degree	IP20

Mechanical specifications

Dimensions (H x W x D)	109 x 23.5 x 130 mm
Weight approx.	230 g
DIN rail type	DIN EN 60715 - 35 mm
Max. wire size	0.13...2.08 mm ² AWG 26...14 stranded wire
Wire stripping length	7 mm
Screw terminal torque	0.5 Nm

Common electrical specifications

Supply voltage, universal	21.6...253 VAC, 50...60 Hz or 19.2...300 VDC
Max. power dissipation	≤ 2 W (2 channels)
Max. required power	≤ 4 W (2 channels)
Fuse	400 mA SB / 250 VAC
Isolation voltage, test / operation	3.75 kVAC / 250 VAC
PELV/SELV	IEC 61140
Programming	DIP switches
Max. frequency	20 Hz

EMC immunity influence	< ±0.5%
Extended EMC immunity: NAMUR NE 21, A criterion, burst	< ±1%

Inputs

NPN and mechanical switch

Trig level LOW	≤ 4.0 VDC
Trig level HIGH	≥ 7.0 VDC
Max. external voltage	28 VDC
Input impedance	3.48 kΩ

PNP

Trig level LOW	≤ 4.0 V
Trig level HIGH	≥ 7.0 V
Max. external voltage	28 VDC
Input impedance	3.48 kΩ

Outputs

Output voltage	See I.S. data table
Output current	See I.S. data table
Output ripple	< 40 mVRMS

I.S. data

Type:	5203B-U9_F	5203B-U9_H	5203B-U9_I
U_m :	250 V	250 V	250 V
U_o :	28 VDC	28 VDC	28 VDC
I_o :	115 mADC	110 mADC	93 mADC
P_o :	0.81 W	0.77 W	0.65 W
L_o :	2 mH	2.6 mH	3 mH
C_o :	0.08 μ F	0.08 μ F	0.08 μ F
Voutput, unloaded min.:	22.0 VDC	22.0 VDC	22.0 VDC
Voutput, loaded min.:	13.0 VDC	14.0 VDC	10.0 VDC
Output current, max.:	50.0 mADC	35.0 mADC	35.0 mADC

Observed authority requirements

EMC. 2014/30/EU
 LVD 2014/35/EU
 RoHS 2011/65/EU

Approvals

c UL us, UL 508. 20170505-E233311
 c UL us, UL 913. 20170505-E233311

DIP switch programming

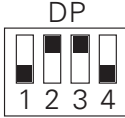
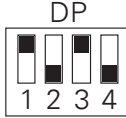
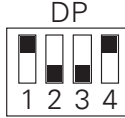
Input: (channel 1 = DP 1, channel 2 = DP 2)			
Open collector PNP, direct	Open collector PNP, inverted	Switch and open collector NPN, direct	Switch and open collector NPN, inverted
On Off 	On Off 	On Off 	On Off 

Block diagram

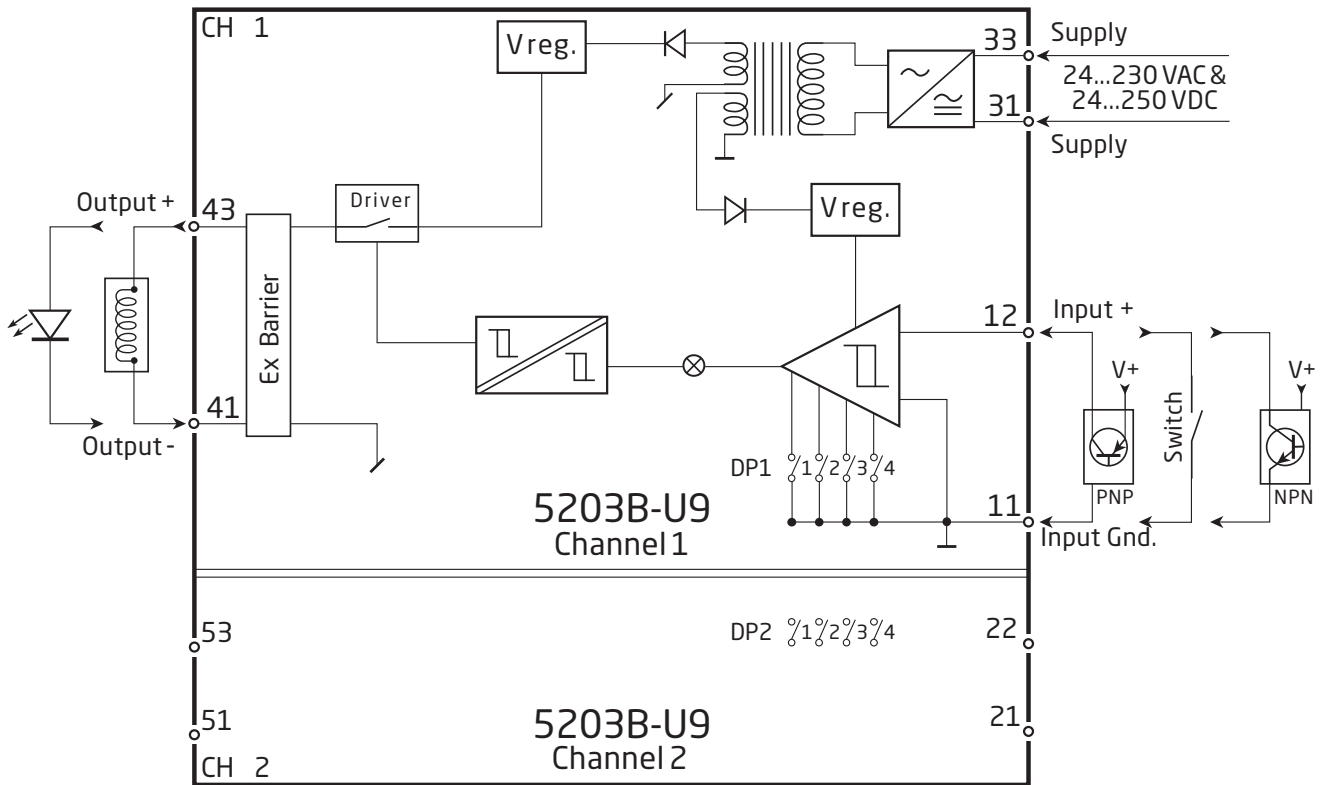

Connections

Supply:

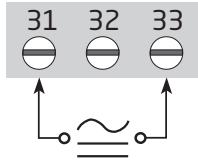

Digital inputs:

Channel 1
Channel 2

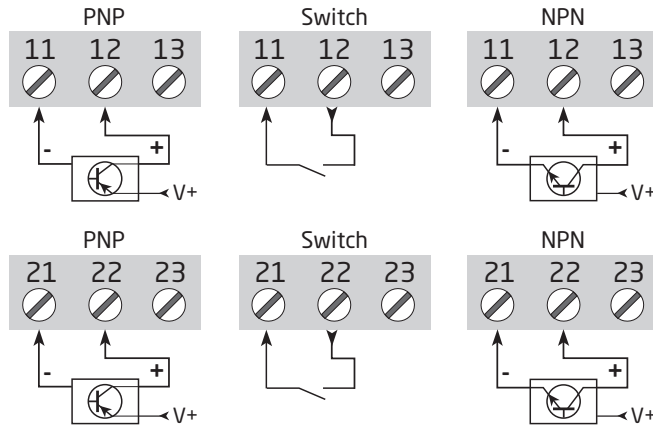

I.S. outputs:

Channel 1
Channel 2

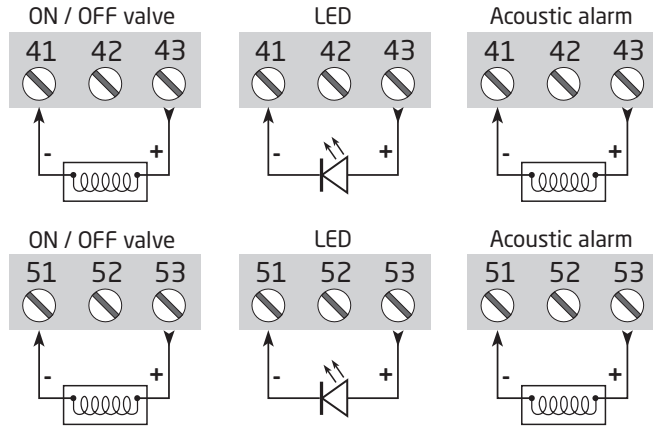

Control Drawing 5203QU01

Hazardous (Classified) Location

Class I, Division 1, Group A,B,C,D
 Class I, Zone 0 and 1, Group IIC
 Class II, Division 1 Group E, F, G

Nonhazardous

Associated apparatus
 Galvanic Isolated

Intrinsically safe apparatus
 entity parameters:

$$V_{max} (U_i) \geq V_t (U_o)$$

$$I_{max} (I_i) \geq I_t (I_o)$$

$$P_i \geq P_o$$

$$C_a \geq C_{cable} + C_i$$

$$L_a \geq L_{cable} + L_i$$

The sum of capacitance and inductance of cable and intrinsic safe equipment must be less or equal to C_a and L_a

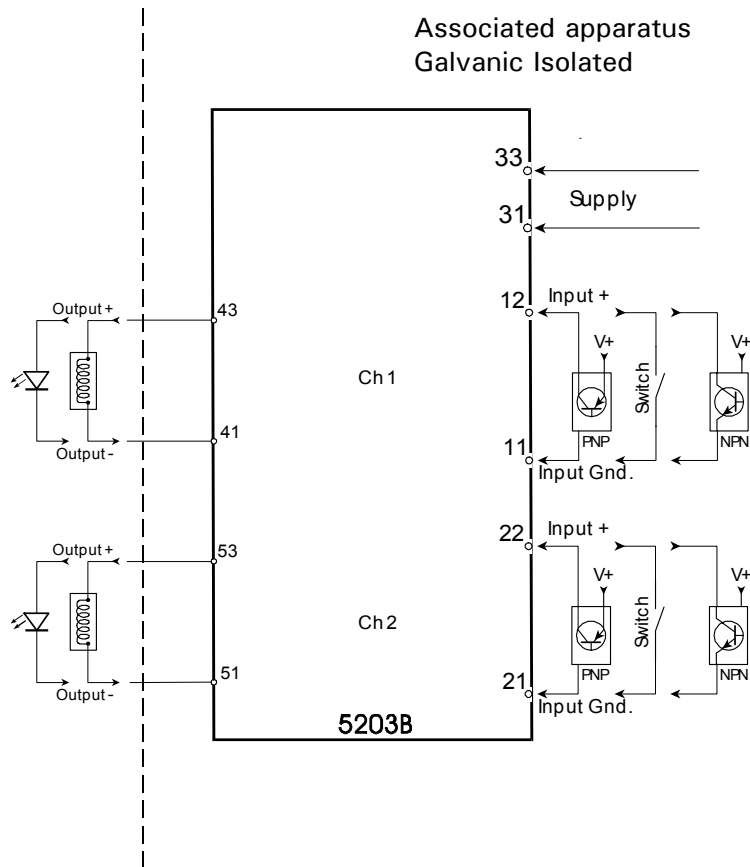

5203B Associated apparatus parameters									
Type	F			H			I		
Vt (Uo)	28 V			28 V			28 V		
It (Io)	115 mA			110 mA			93 mA		
Po	0.81 W			0.77 W			0,65 W		
Group	A,B and IIC	C and IIB	D and IIA	A,B and IIC	C and IIB	D and IIA	A,B and IIC	C and IIB	D and IIA
La (Lo)	1.6 mH	5.0 mH	16mH	2.0 mH	8 mH	20 mH	2.4 mH	9 mH	25 mH
Ca (Co)	0.06 μF	0.52 μF	1.7μF	0.06μF	0.52 μF	1.7μF	0.06 μF	0.52 μF	1.7μF

Installation notes:

- 1) The maximum nonhazardous location voltage is 250Vac/dc.
- 2) The installation shall be in accordance with the National Electrical Code NFPA 70, Articles 504 and 505.
- 3) The terminals of the two individual channels shall not be interconnected in any way.
- 4) Install in Pollution degree 2 or better
- 5) Use 60 / 75 °C Copper Conductors with Wire Size AWG: (26 – 14).
- 6) Warning: Substitution of components may impair intrinsic safety.
- 7) If cable parameters are unknown C_{cable} may be set to 60pF/ft and L_{cable} may be set to 0.20 μH/ft

Rev. AA 2003-09-19

Document history

The following list provides notes concerning revisions of this document.

Rev. ID	Date	Notes
106	2535	New EAC Ex certificate.
107	2540	Model 5203B-U9 released.

We are near you, *all over the world*

Our trusted red boxes are supported wherever you are

All our devices are backed by expert service and a 5-year warranty. With each product you purchase, you receive personal technical support and guidance, day-to-day delivery, repair without charge within the warranty period and easily accessible documentation.

We are headquartered in Denmark, and have offices and authorized partners the world over. We are a local business

with a global reach. This means that we are always nearby and know your local markets well.

We are committed to your satisfaction and provide PERFORMANCE MADE SMARTER all around the world.

For more information on our warranty program, or to meet with a sales representative in your region, visit prelectronics.com.

Benefit today from *PERFORMANCE MADE SMARTER*

PR electronics is the leading technology company specialized in making industrial process control safer, more reliable and more efficient. Since 1974, we have been dedicated to perfecting our core competence of innovating high precision technology with low power consumption. This dedication continues to set new standards for products communicating, monitoring and connecting our customers' process measurement points to their process control systems.

Our innovative, patented technologies are derived from our extensive R&D facilities and from having a great understanding of our customers' needs and processes. We are guided by principles of simplicity, focus, courage and excellence, enabling some of the world's greatest companies to achieve PERFORMANCE MADE SMARTER.