

PERFORMANCE  
MADE  
SMARTER

Product manual

**5332**

**2-wire programmable  
RTD transmitter**



TEMPERATURE | I.S. INTERFACES | COMMUNICATION INTERFACES | MULTIFUNCTIONAL | ISOLATION | DISPLAY

No. 5332V106-UK  
Serial no: 241070167-261492216

**PR**  
electronics

# 6 Product Pillars

## *to meet your every need*

### Individually outstanding, unrivalled in combination

With our innovative, patented technologies, we make signal conditioning smarter and simpler. Our portfolio is composed of six product areas, where we offer a wide range of analog and digital devices covering over a thousand applications in industrial and factory automation. All our products comply with or surpass the highest industry standards, ensuring reliability in even the harshest of environments and have a 5-year warranty for greater peace of mind.



Our range of temperature transmitters and sensors provides the highest level of signal integrity from the measurement point to your control system. You can convert industrial process temperature signals to analog, bus or digital communications using a highly reliable point-to-point solution with a fast response time, automatic self-calibration, sensor error detection, low drift, and top EMC performance in any environment.



We deliver the safest signals by validating our products against the toughest safety standards. Through our commitment to innovation, we have made pioneering achievements in developing I.S. interfaces with SIL 2 Full Assessment that are both efficient and cost-effective. Our comprehensive range of analog and digital intrinsically safe isolation barriers offers multifunctional inputs and outputs, making PR an easy-to-implement site standard. Our backplanes further simplify large installations and provide seamless integration to standard DCS systems.



We provide inexpensive, easy-to-use, future-ready communication interfaces that can access your PR installed base of products. All the interfaces are detachable, have a built-in display for readout of process values and diagnostics, and can be configured via push-buttons. Product specific functionality includes communication via Modbus and Bluetooth and remote access using our PR Process Supervisor (PPS) application, available for iOS and Android.



Our unique range of single devices covering multiple applications is easily deployable as your site standard. Having one variant that applies to a broad range of applications can reduce your installation time and training, and greatly simplify spare parts management at your facilities. Our devices are designed for long-term signal accuracy, low power consumption, immunity to electrical noise and simple programming.



Our compact, fast, high-quality 6 mm isolators are based on microprocessor technology to provide exceptional performance and EMC-immunity for dedicated applications at a very low total cost of ownership. They can be stacked both vertically and horizontally with no air gap separation between units required.



Our display range is characterized by its flexibility and stability. The devices meet nearly every demand for display readout of process signals and have universal input and power supply capabilities. They provide a real-time measurement of your process value no matter the industry and are engineered to provide a user-friendly and reliable relay of information, even in demanding environments.

# 2-wire programmable RTD transmitter 5332

## Table of contents

Application .....	4
Technical characteristics .....	4
Mounting / installation .....	4
Applications .....	4
Order .....	5
Accessories .....	5
Electrical specifications .....	5
Connections .....	7
Block diagram .....	7
Programming .....	8
Mechanical specifications .....	8
Mounting of sensor wires .....	8
ATEX Installation Drawing - 5332A .....	9
ATEX Installation Drawing - 5332D .....	11
IECEX Installation Drawing - 5332A .....	13
IECEX Installation Drawing - 5332D .....	15
FM Installation Drawing - 5332D .....	17
CSA Installation Drawing - 5332A .....	19
CSA Installation Drawing - 5332D .....	20
Desenho de instalação INMETRO - 5332A .....	21
Desenho de instalação INMETRO - 5332D .....	23
Document history .....	25

# 2-wire programmable RTD transmitter 5332

- RTD or Ohm input
- Accuracy: Better than 0.05% of selected range
- Programmable sensor error value
- For DIN form B sensor head mounting

## Application

- Linearised temperature measurement with Pt100... Pt1000 or Ni100...Ni1000 sensor.
- Conversion of linear resistance variation to a standard analogue current signal, for instance from valves or Ohmic level sensors.

## Technical characteristics

- Within a few seconds the user can program PR5332 to measure temperatures within all ranges defined by the norms.
- Dedicated programmable non-isolated 4-wire RTD transmitter.
- RTD and resistance inputs have cable compensation for 2-, 3- and 4-wire connection.
- Continuous check of vital stored data for safety reasons.

## Mounting / installation

- For DIN form B sensor head mounting. In non-hazardous areas the 5332 can be mounted on a DIN rail with the PR fitting type 8421.

## Applications

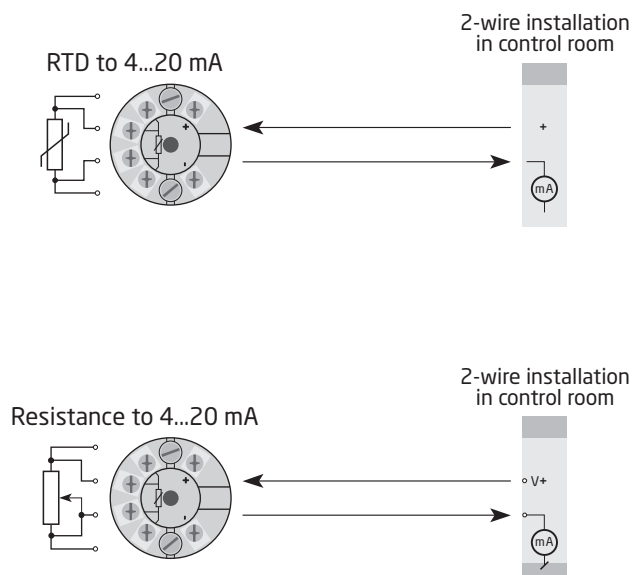

## Order

Type	Version
5332	Simple, no approvals : N
	Zone 2 / Div. 2 : A
	Zone 0, 1, 2, 21, 22, M1 / DIV. 1, DIV. 2 : D

## Accessories

5909 = Loop Link USB interface and PReset Software
--

## Electrical specifications

### Environmental conditions:

Operating temperature . . . . .	-40°C to +85°C
Calibration temperature . . . . .	20...28°C
Relative humidity . . . . .	< 95% RH (non-cond.)
Protection degree (encl./terminal) . . . . .	IP68 / IP00

### Mechanical specifications:

Dimensions . . . . .	Ø 44 x 20.2 mm
Weight . . . . .	50 g
Max. wire size . . . . .	1 x1.5 mm <sup>2</sup> stranded wire
Screw terminal torque . . . . .	0.4 Nm

### Common specifications:

Supply voltage, DC	
5332N & 5332A . . . . .	7.2...35 VDC
5332D . . . . .	7.2...30 VDC
Internal power dissipation	
5332N & 5332A . . . . .	25 mW...0.8 W
5332D . . . . .	25 mW...0.7 W
Voltage drop . . . . .	7.2 VDC
Warm-up time . . . . .	5 min.
Power on to stable output . . . . .	4.5 s
Programming . . . . .	Loop Link
Signal / noise ratio . . . . .	> 60 dB
Response time (programmable) . . . . .	1...60 s
EEPROM error check . . . . .	< 3.5 s
Signal dynamics, input . . . . .	20 bit
Signal dynamics, output . . . . .	16 bit
Effect of supply voltage variation . . . . .	< 0.005% of span / VDC

Accuracy, the greater of general and basic values:

General values		
Input type	Absolute accuracy	Temperature coefficient
All	≤ ±0.05% of span	≤ ±0.01% of span / °C

Basic values		
Input type	Basic accuracy	Temperature coefficient
RTD	≤ ±0.2°C	≤ ±0.01°C/°C
Lin. R	≤ ±0.1 Ω	≤ ±10 mΩ / °C

EMC - immunity influence. . . . .	< ±0.5% of span
Extended EMC immunity: NAMUR NE 21, A criterion, burst . . . . .	< ±1% of span

**Input specifications:**

**RTD and linear resistance input:**

RTD type	Min. value	Max. value	Min. span	Standard
Pt100...Pt1000	-200°C	+850°C	25°C	IEC 60751
Ni100...Ni1000	-60°C	+250°C	25°C	DIN 43760
Linear resistance	0 Ω	5000 Ω	30 Ω	-----

Max. offset . . . . .	50% of selec. max. value
Cable resistance per wire (max.). . . . .	5 Ω
Sensor current . . . . .	Nom. 0.2 mA
Effect of sensor cable resistance (3- / 4-wire) . . . . .	< 0.002 Ω/Ω
Sensor error detection . . . . .	Yes

**Output specifications:**

**Current output:**

Signal range. . . . .	4...20 mA
Min. signal range. . . . .	16 mA
Updating time . . . . .	440 ms
Load resistance. . . . .	≤ (V <sub>supply</sub> - 7.2) / 0.023 [Ω]
Load stability . . . . .	< ±0.01% of span / 100 Ω

**Sensor error detection:**

Programmable . . . . .	3.5...23 mA
NAMUR NE43 Upscale . . . . .	23 mA
NAMUR NE43 Downscale. . . . .	3.5 mA

Of span = Of the presently selected range

**Observed authority requirements:**

EMC. . . . .	2014/30/EU & UK SI 2016/1091
ATEX . . . . .	2014/34/EU & UK SI 2016/1107
RoHS . . . . .	2011/65/EU & UK SI 2012/3032
EAC . . . . .	TR-CU 020/2011
EAC Ex . . . . .	TR-CU 012/2011

**Ex / I.S. approvals:**

5332A:	
ATEX . . . . .	DEKRA 20ATEX0096X
5332D:	
ATEX . . . . .	DEKRA 20ATEX0095X
FM . . . . .	FM17US0013X
5332A & 5332D:	
IECEX. . . . .	DEK 20.0059X
CSA. . . . .	1125003
INMETRO . . . . .	DEKRA 23.0009X
EAC Ex. . . . .	EAEU KZ 7500361.01.01.08756

# Connections

## Input:

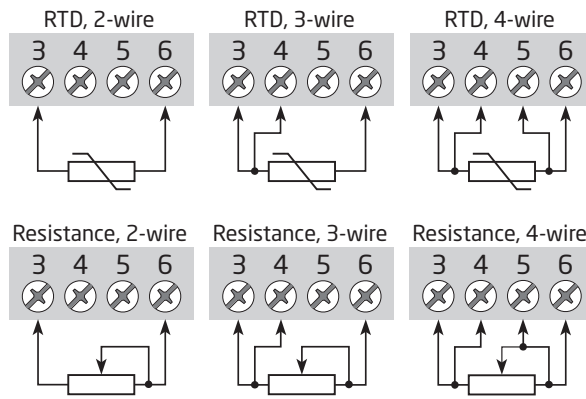

## Output:

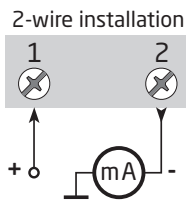

# Block diagram

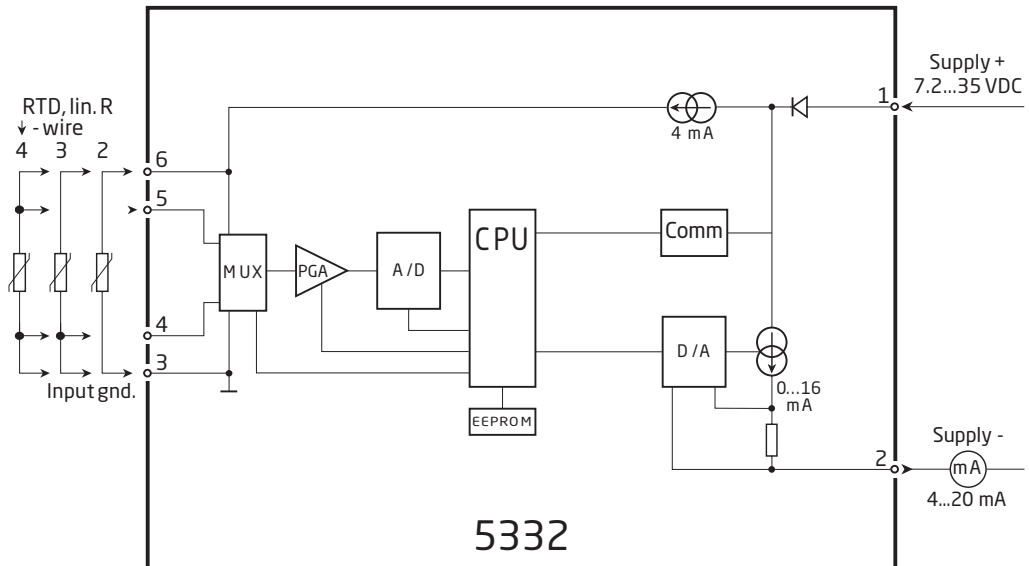

# Programming

- Loop Link is a communications interface that is needed for programming 5332.
- For programming please refer to the drawing below and the help functions in PReset.
- Loop link is not approved for communication with modules installed in hazardous (Ex) areas.

## Order: Loop Link

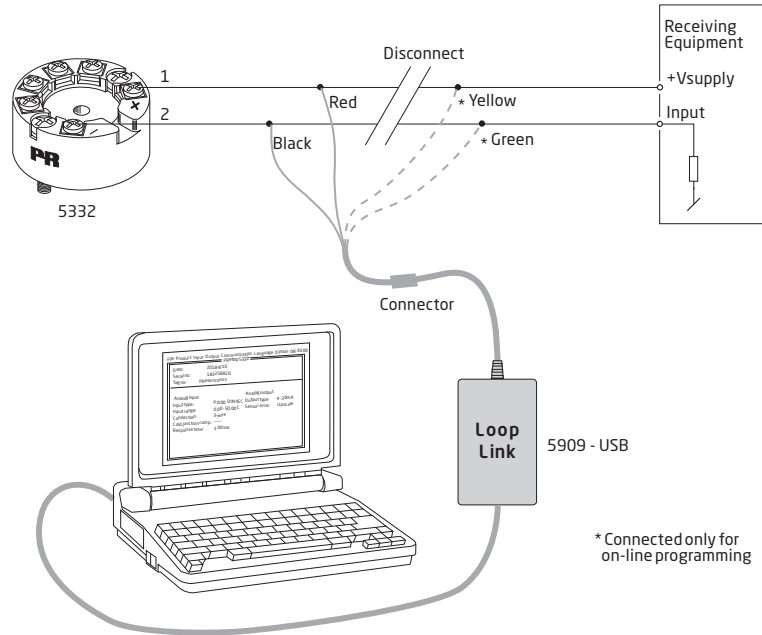

## Mechanical specifications

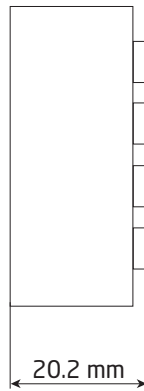
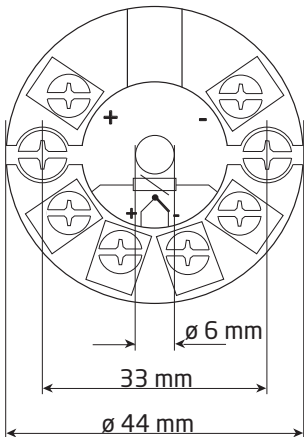

## Mounting of sensor wires

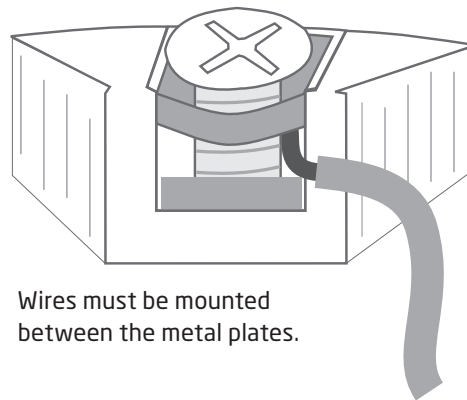

# ATEX-installation drawing 5332QA02-V2R0

For safe installation of 5332A the following must be observed. The module shall only be installed by qualified personnel who are familiar with the national and international laws, directives and standards that apply to this area. Year of manufacture can be taken from the first two digits in the serial number.

ATEX Certificate      DEKRA 20ATEX0096 X

Marking



II 3 G Ex nA [ic] IIC T6 ... T4 Gc  
 II 3 G Ex ec [ic] IIC T6 ... T4 Gc  
 II 3 G Ex ic IIC T6 ... T4 Gc  
 II 3 D Ex ic IIIC Dc

Standards

EN 60079-0: 2018, EN 60079-11: 2012,  
 EN 60079-15: 2010, EN 60079-7:2015 +A1: 2018

Terminal 3,4,5,6	Terminal 1,2	Terminal 1,2	Terminal 1,2
Ex ic IIC, Ex ic IIIC	Ex ic IIC, Ex ic IIIC	Ex ic IIC, Ex ic IIIC	Ex nA, Ex ec
U <sub>o</sub> : 9.6 V I <sub>o</sub> : 25 mA P <sub>o</sub> : 60 mW L <sub>o</sub> : 33 mH C <sub>o</sub> : 2.4 µF	U <sub>i</sub> = 35 V I <sub>i</sub> = 110 mA C <sub>i</sub> = 1 nF L <sub>i</sub> = 10 µH	U <sub>i</sub> = 24 V I <sub>i</sub> = 260 mA C <sub>i</sub> = 1 nF L <sub>i</sub> = 10 µH	U <sub>max</sub> ≤ 35 VDC or U <sub>max</sub> ≤ 24 VDC

Ex ic IIC, Ex ic IIIC Temperature Class	Ambient temperature range	
	U <sub>i</sub> =35 V	U <sub>i</sub> =24 V
<b>T6</b>	-40°C to +54°C	-40°C to +63°C
<b>T5</b>	-40°C to +69°C	-40°C to +78°C
<b>T4</b>	-40°C to +85°C	-40°C to +85°C

Ex ec, Ex nA Temperature Class	Ambient temperature range	
	V <sub>max</sub> =35 V	V <sub>max</sub> =24 V
<b>T6</b>	-40°C to +43°C	-40°C to +55°C
<b>T5</b>	-40°C to +85°C	-40°C to +85°C
<b>T4</b>	-40°C to +85°C	-40°C to +85°C

## Installation notes

If the enclosure is made of non-metallic plastic materials, electrostatic charges on the transmitter enclosure shall be avoided.

If the transmitter is installed in an explosive atmosphere requiring the use of equipment protection level Gc and applied in type of protection Ex ic, the transmitter shall be mounted in an enclosure that provides a degree of protection of at least IP20 according to EN 60529, and that is suitable for the application and correctly installed.

If the transmitter is installed in an explosive atmosphere requiring the use of equipment protection level Dc, the transmitter shall be mounted in a separately certified enclosure that provides a degree of protection of at least IP5X according to EN 60079-0, and that is suitable for the application and correctly installed. The surface temperature of the outer enclosure is +20 K above the ambient temperature, determined without a dust layer. Ambient temperature range: -40°C to +85°C.

If the transmitter is installed in an explosive atmosphere requiring the use of equipment protection level Gc and applied in type of protection Ex nA or Ex ec, the transmitter shall be mounted in a separately certified enclosure that provides a degree of protection of at least IP54 according to EN 60079-0, and that is suitable for the application and correctly installed.

If the transmitter is installed in an explosive atmosphere requiring the use of equipment protection level Gc and applied in type of protection Ex nA or Ex ec, the equipment shall only be used in an area of not more than pollution degree 2, as defined in EN 60664-1.

# ATEX-installation drawing 5332QA01-V2R0



For safe installation of 5332D the following must be observed. The module shall only be installed by qualified personnel who are familiar with the national and international laws, directives and standards that apply to this area. Year of manufacture can be taken from the first two digits in the serial number.

ATEX Certificate      DEKRA 20ATEX0095 X

Marking



II 1 G Ex ia IIC T6...T4 Ga  
II 2 D Ex ia IIIC Db  
I M1 Ex ia I Ma

Standards              EN 60079-0: 2018, EN 60079-11: 2012

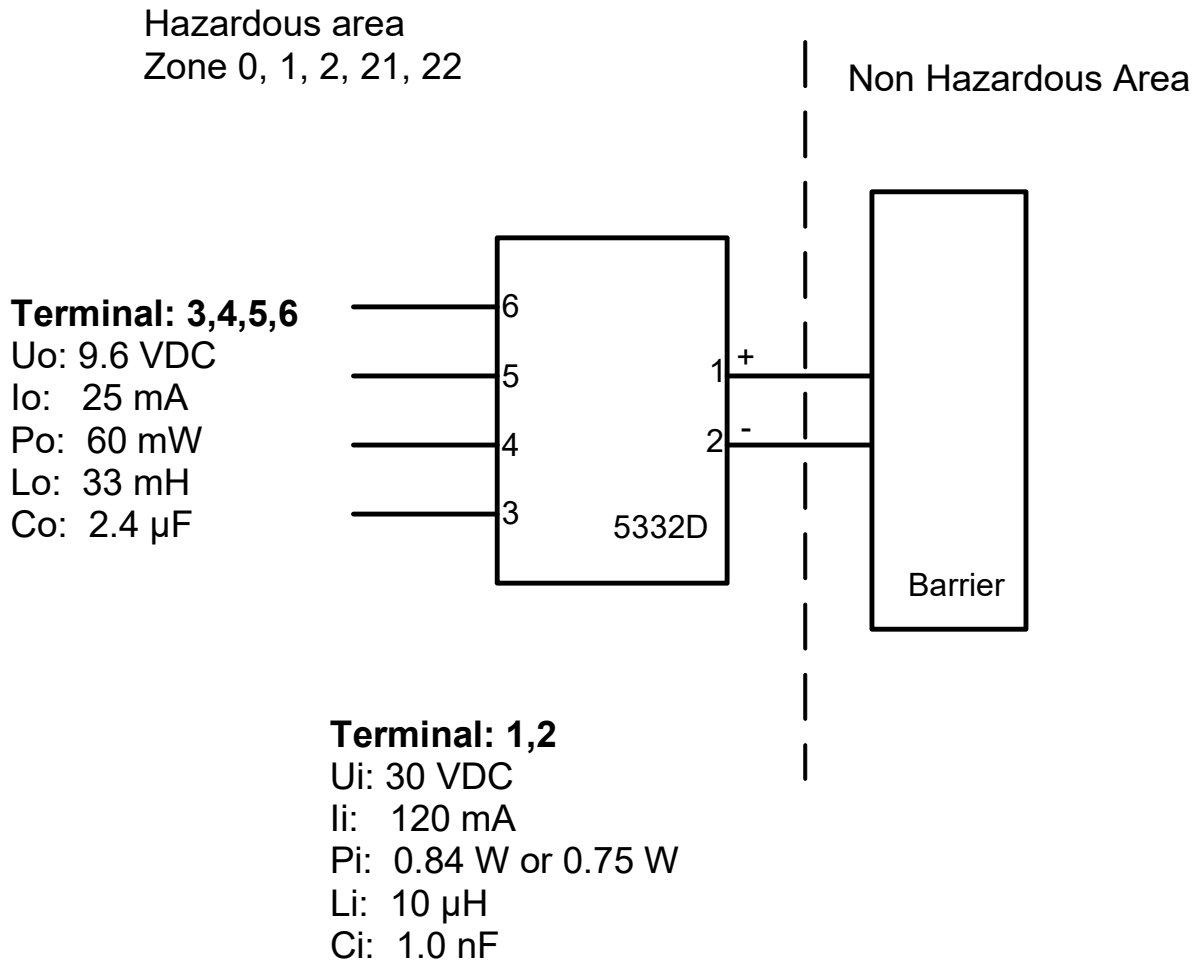

Temperature Class	Ambient temperature range	
	Pi: 0.84 W	Pi: 0.75 W
<b>T6</b>	-40°C to +47°C	-40°C to +50°C
<b>T5</b>	-40°C to +62°C	-40°C to +65°C
<b>T4</b>	-40°C to +85°C	-40°C to +85°C

## Installation notes

If the enclosure is made of non-metallic plastic materials, electrostatic charges on the transmitter enclosure shall be avoided.

If the transmitter is installed in an explosive atmosphere requiring the use of equipment protection level Ga, the transmitter shall be mounted in an enclosure that provides a degree of protection of at least IP20 according to EN 60529, and that is suitable for the application and correctly installed.

If the transmitter is installed in an explosive atmosphere requiring the use of equipment protection level Ga or Ma, and if the enclosure is made of aluminum, it must be installed such, that ignition sources due to impact and friction sparks are excluded.

If the transmitter is installed in an explosive atmosphere requiring the use of equipment protection level Db, the transmitter shall be mounted in a separately certified enclosure that provides a degree of protection of at least IP5X according to EN 60079-0, and that is suitable for the application and correctly installed.

If the transmitter is installed in an explosive atmosphere requiring the use of equipment protection level Ma, the transmitter shall be mounted in an enclosure that provides a degree of protection of at least IP54 according to EN 60529, and that is suitable for the application and correctly installed.

Cable entries and blanking elements shall be used that are suitable for the application and correctly installed.

For an ambient temperature  $\geq 60^{\circ}\text{C}$ , heat resistant cables shall be used with a rating of at least 20 K above the ambient temperature.

# IECEX-installation drawing 5332QI02-V2R0

For safe installation of 5332A the following must be observed. The module shall only be installed by qualified personnel who are familiar with the national and international laws, directives and standards that apply to this area. Year of manufacture can be taken from the first two digits in the serial number.

Certificate IECEX DEK 20.0059X

Marking  
 Ex nA [ic] IIC T6 ... T4 Gc  
 Ex ec [ic] IIC T6 ... T4 Gc  
 Ex ic IIC T6 ... T4 Gc  
 Ex ic IIIC Dc

Standards IEC 60079-0: 2017, IEC 60079-11: 2011,  
 IEC 60079-15: 2010, IEC 60079-7:2017

Terminal 3,4,5,6	Terminal 1,2	Terminal 1,2	Terminal 1,2
Ex ic IIC, Ex ic IIIC	Ex ic IIC, Ex ic IIIC	Ex ic IIC, Ex ic IIIC	Ex nA, Ex ec
Uo: 9.6 V Io: 25 mA Po: 60 mW Lo: 33 mH Co: 2.4 µF	Ui = 35 V Ii = 110 mA Ci = 1 nF Li = 10 µH	Ui = 24 V Ii = 260 mA Ci = 1 nF Li = 10 µH	Umax ≤ 35 VDC or Umax ≤ 24 VDC

Ex ic IIC, Ex ic IIIC Temperature Class	Ambient temperature range	
	Ui=35 V	Ui=24 V
<b>T6</b>	-40°C to +54°C	-40°C to +63°C
<b>T5</b>	-40°C to +69°C	-40°C to +78°C
<b>T4</b>	-40°C to +85°C	-40°C to +85°C

Ex ec, Ex nA Temperature Class	Ambient temperature range	
	Vmax=35 V	Vmax=24 V
<b>T6</b>	-40°C to +43°C	-40°C to +55°C
<b>T5</b>	-40°C to +85°C	-40°C to +85°C
<b>T4</b>	-40°C to +85°C	-40°C to +85°C

## Installation notes

If the enclosure is made of non-metallic plastic materials, electrostatic charges on the transmitter enclosure shall be avoided.

If the transmitter is installed in an explosive atmosphere requiring the use of equipment protection level Gc and applied in type of protection Ex ic, the transmitter shall be mounted in an enclosure that provides a degree of protection of at least IP20 according to IEC 60529, and that is suitable for the application and correctly installed.

If the transmitter is installed in an explosive atmosphere requiring the use of equipment protection level Dc, the transmitter shall be mounted in a separately certified enclosure that provides a degree of protection of at least IP5X according to IEC 60079-0, and that is suitable for the application and correctly installed. The surface temperature of the outer enclosure is +20 K above the ambient temperature, determined without a dust layer.  
Ambient temperature range: -40°C to +85°C.

If the transmitter is installed in an explosive atmosphere requiring the use of equipment protection level Gc and applied in type of protection Ex nA or Ex ec, the transmitter shall be mounted in a separately certified enclosure that provides a degree of protection of at least IP54 according to IEC 60079-0, and that is suitable for the application and correctly installed.

If the transmitter is installed in an explosive atmosphere requiring the use of equipment protection level Gc and applied in type of protection Ex nA or Ex ec, the equipment shall only be used in an area of not more than pollution degree 2, as defined in IEC 60664-1.

# IECEX-installation drawing 5332QI01-V2R0



For safe installation of 5332D the following must be observed. The module shall only be installed by qualified personnel who are familiar with the national and international laws, directives and standards that apply to this area. Year of manufacture can be taken from the first two digits in the serial number.

Certificate	IECEX DEK 20.0059X
Marking	Ex ia IIC T6...T4 Ga Ex ia IIIC Db Ex ia I Ma
Standards	IEC 60079-0: 2017, IEC 60079-11: 2011

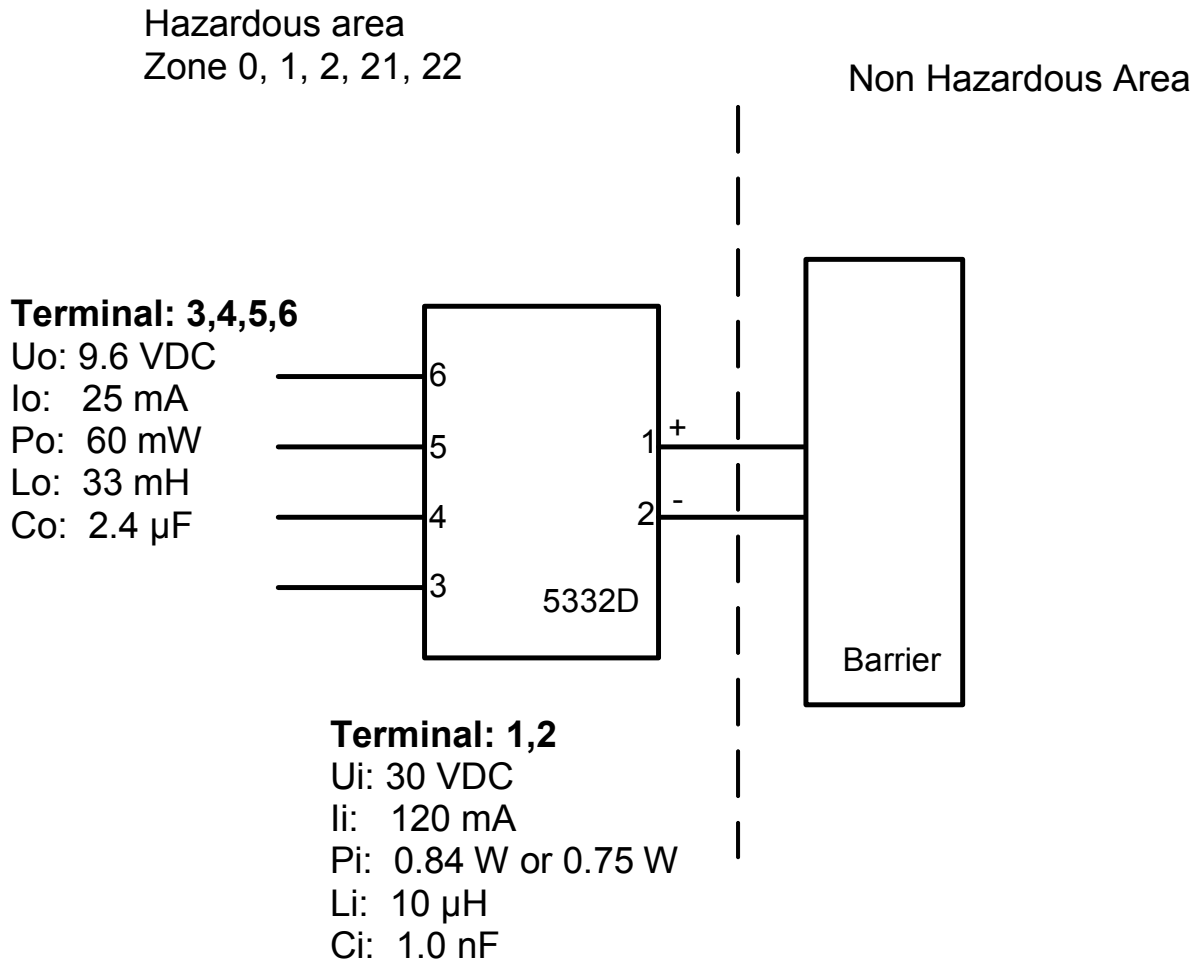

Temperature Class	Ambient temperature range	
	Pi: 0.84 W	Pi: 0.75 W
<b>T6</b>	-40°C to +47°C	-40°C to +50°C
<b>T5</b>	-40°C to +62°C	-40°C to +65°C
<b>T4</b>	-40°C to +85°C	-40°C to +85°C

## Installation notes

If the enclosure is made of non-metallic plastic materials, electrostatic charges on the transmitter enclosure shall be avoided.

If the transmitter is installed in an explosive atmosphere requiring the use of equipment protection level Ga, the transmitter shall be mounted in an enclosure that provides a degree of protection of at least IP20 according to IEC 60529, and that is suitable for the application and correctly installed.

If the transmitter is installed in an explosive atmosphere requiring the use of equipment protection level Ga or Ma, and if the enclosure is made of aluminum, it must be installed such, that ignition sources due to impact and friction sparks are excluded.

If the transmitter is installed in an explosive atmosphere requiring the use of equipment protection level Db, the transmitter shall be mounted in a separately certified enclosure that provides a degree of protection of at least IP5X according to IEC 60079-0, and that is suitable for the application and correctly installed. The surface temperature of the outer enclosure is +20 K above the ambient temperature, determined without a dust layer.  
Ambient temperature range: -40°C to +85°C.

If the transmitter is installed in an explosive atmosphere requiring the use of equipment protection level Ma, the transmitter shall be mounted in an enclosure that provides a degree of protection of at least IP54 according to IEC 60529, and that is suitable for the application and correctly installed.  
Ambient temperature range: -40°C to +85°C.

Cable entries and blanking elements shall be used that are suitable for the application and correctly installed.

For an ambient temperature  $\geq 60^\circ\text{C}$ , heat resistant cables shall be used with a rating of at least 20 K above the ambient temperature.

## FM Installation Drawing

### Model 5331D, 5332D, 5333D and 5343B

#### Hazardous (Classified) Location

Class I, Division 1, Groups, A, B, C, D T4..T6  
Class I, Zone 0, AEx ia IIC T4..T6

Ambient temperature limits  
T4: -40 to +85 deg. Celcius  
T6: -40 to +60 deg. Celcius

Terminal 1, 2  
Vmax or Ui: 30 V  
Imax or Ii: 120 mA  
Pmax or Pi: 0.84 W  
Ci: 1 nF  
Li: 10 uH

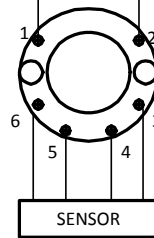

#### Non Hazardous Location

Associated Apparatus  
or Barrier  
with  
entity Parameters:

$UM \leq 250V$   
 $V_{oc} \text{ or } U_o \leq V_{max} \text{ or } U_i$   
 $I_{sc} \text{ or } I_o \leq I_{max} \text{ or } I_i$   
 $P_o \leq P_i$   
 $C_a \text{ or } C_o \geq C_i + C_{cable}$   
 $L_a \text{ or } L_o \geq L_i + L_{cable}$

This device must not be connected  
to any associated apparatus which  
uses or generates more than 250  
VRMS

### Model 5335D, 5337D

#### Hazardous (Classified) Location

Class I, Division 1, Groups, A, B, C, D T4..T6  
Class I, Zone 0, AEx ia IIC T4..T6

Ambient temperature limits  
T4: -40 to +85 deg. Celcius  
T6: -40 to +60 deg. Celcius

Terminal 1, 2  
Vmax or Ui: 30 V  
Imax or Ii: 120 mA  
Pmax or Pi: 0.84 W  
Ci: 1 nF  
Li: 10 uH

Terminal 3,4,5,6  
Vt or Uo: 9.6 V  
It or Io: 28 mA  
Pt or Po: 67.2 mW  
Ca or Co: 3.5 uF  
La or Lo: 35 mH

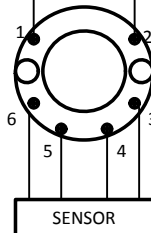

#### Non Hazardous Location

Associated Apparatus  
or Barrier  
with  
entity Parameters:

$UM \leq 250V$   
 $V_{oc} \text{ or } U_o \leq V_{max} \text{ or } U_i$   
 $I_{sc} \text{ or } I_o \leq I_{max} \text{ or } I_i$   
 $P_o \leq P_i$   
 $C_a \text{ or } C_o \geq C_i + C_{cable}$   
 $L_a \text{ or } L_o \geq L_i + L_{cable}$

This device must not be connected  
to any associated apparatus which  
uses or generates more than 250  
VRMS

**The entity concept**

The Transmitter must be installed according to National Electrical Code (ANSI-NFPA 70) and shall be installed with the enclosure, mounting, and spacing segregation requirement of the ultimate application.

Equipment that is FM-approved for intrinsic safety may be connected to barriers based on the ENTITY CONCEPT. This concept permits interconnection of approved transmitters, meters and other devices in combinations which have not been specifically examined by FM, provided that the agency's criteria are met. The combination is then intrinsically safe, if the entity concept is acceptable to the authority having jurisdiction over the installation.

The entity concept criteria are as follows:

The intrinsically safe devices, other than barriers, must not be a source of power.  
 The maximum voltage  $U_i(V_{MAX})$  and current  $I_i(I_{MAX})$ , and maximum power  $P_i(P_{MAX})$ , which the device can receive and remain intrinsically safe, must be equal to or greater than the voltage ( $U_o$  or  $V_{OC}$  or  $V_t$ ) and current ( $I_o$  or  $I_{SC}$  or  $I_t$ ) and the power  $P_o$  which can be delivered by the barrier.

The sum of the maximum unprotected capacitance ( $C_i$ ) for each intrinsically device and the interconnecting wiring must be less than the capacitance ( $C_a$ ) which can be safely connected to the barrier.

The sum of the maximum unprotected inductance ( $L_i$ ) for each intrinsically device and the interconnecting wiring must be less than the inductance ( $L_a$ ) which can be safely connected to the barrier.

The entity parameters  $U_o, V_{OC}$  or  $V_t$  and  $I_o, I_{SC}$  or  $I_t$ , and  $C_a$  and  $L_a$  for barriers are provided by the barrier manufacturer.

**NI Field Circuit Parameters**

**Model 5331D, 5332D, 5333D, 5335D, 5337D and 5343B**

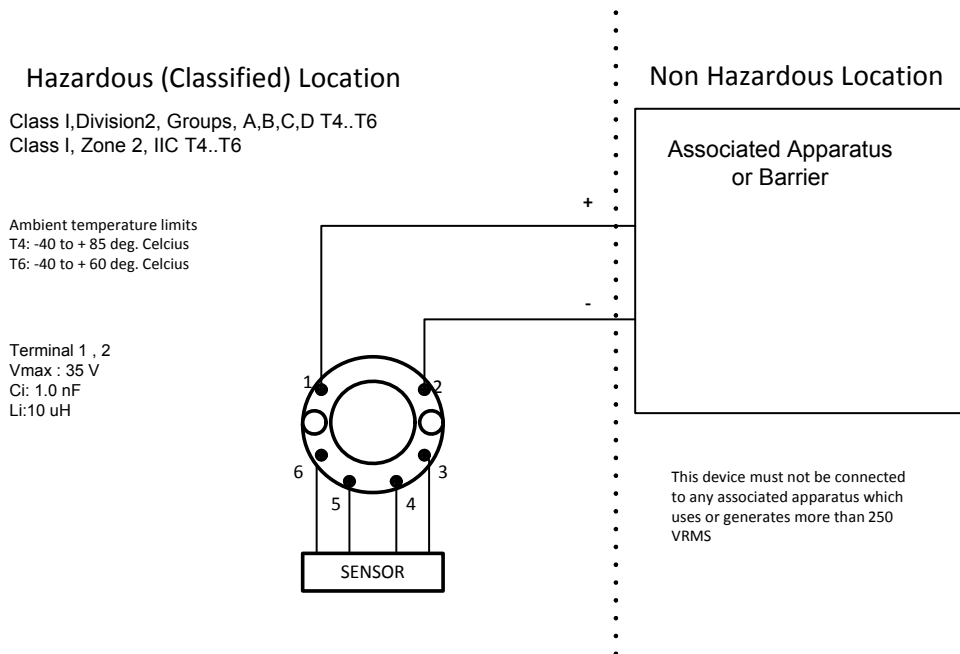

For safe installation of the 5331A and 5332A the following must be observed. The module shall only be installed by qualified personnel who are familiar with the national and international laws, directives and standards that apply to this area.

### Marking

Class I, Division 2, Group A,B,C,D T6...T4  
 Ex nA[ic] IIC T6...T4  
 Class I Zone 2 AEx nA[ic] IIC T6...T4

### Hazardous Area

CL I, Div 2, GP ABCD  
 CL I, Zone 2, IIC

T4: -40°C to 85 °C

T6: -40°C to 60 °C

### Terminal:

**3,4,5,6**

U<sub>o</sub>: 9.6 VDC

I<sub>o</sub>: 25 mA

P<sub>o</sub>: 60 mW

L<sub>o</sub>: 33 mH

C<sub>o</sub>: 2.4µF

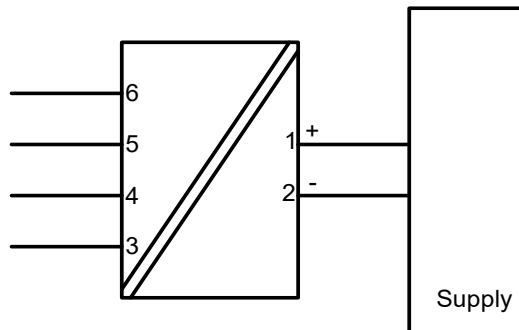

### Terminal:

**1-2**

Functional Ratings:

U nominal ≤ 35 VDC;

I nominal ≤ 3.5 - 23 mA

## NI Installation instructions

The transmitter must be installed in an enclosure providing a degree of protection of at least IP54 according to IEC60529 that is suitable for the application and is correctly installed. Cable entry devices and blanking elements shall fulfill the same requirements.

If the enclosure is made of non-metallic materials or of painted metal, electrostatic charging shall be avoided.

Use supply wires with a rating of at least 5 K above the ambient temperature.

Supply from a Class 2 Power Supply with Transient protection or equivalent.

WARNING: Substitution of components may impair suitability for Class I, Division 2

AVERTISSEMENT: la substitution de composants peut nuire à l'aptitude à la Classe I, Division 2.

WARNING: Do not disconnect equipment unless power has been switched off or the area is known to be safe.

AVERTISSEMENT: Ne débranchez pas l'équipement sauf si l'alimentation a été coupée ou si la zone est connue pour être sûre.

## Non Incendive field wiring installation

The non incendive field Wiring Circuit concept allows interconnection of Nonincendive Field wiring Apparatus with Associated Nonincendive Field Wiring Apparatus or Associated Intrinsically Safe Apparatus or Associated Apparatus not specially examined in combination as a system using any of the wiring methods permitted for unclassified locations,

$Voc < Vmax$ ,  $Ca \geq Ci + Ccable$ ,  $La \geq Li + Lcable$ .

## CSA Installation drawing 5332QC01

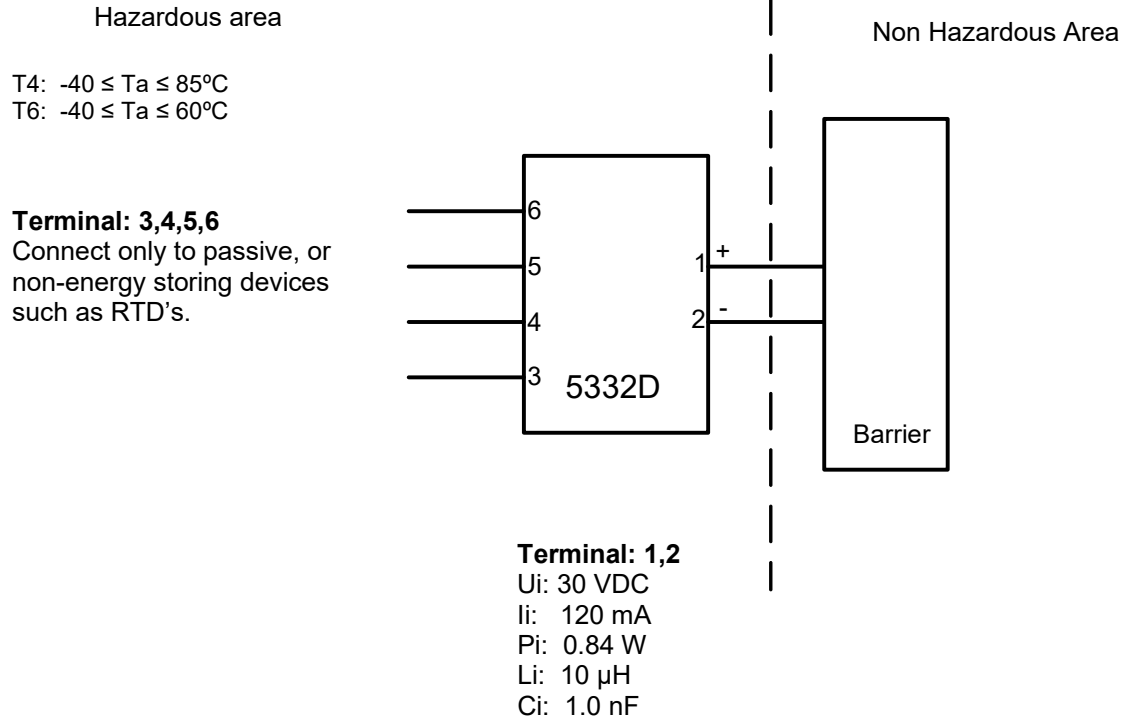

**CLASS 2258 04 - PROCESS CONTROL EQUIPMENT** - Intrinsically Safe Entity - For Hazardous Locations

**CLASS 2258 84 - PROCESS CONTROL EQUIPMENT** - Intrinsically Safe Entity - For Hazardous Locations - Certified to US Standards

Class I, Division 1, Groups A, B, C and D T6...T4

Ex ia IIC T6...T4 Ga

Class I, Zone 0, AEx ia IIC Ga

**Warning:**

Substitution of components may impair intrinsic safety.

The transmitters must be installed in a suitable enclosure to meet installation codes stipulated in the Canadian Electrical Code (CEC) or for US the National Electrical Code (NEC).

## Desenho de Instalação INMETRO



Para instalação segura do 5332A o seguinte deve ser observado. O modelo deve apenas ser instalado por pessoas qualificadas que são familiarizadas com as leis nacionais e internacionais, diretrizes e padrões que se aplicam a esta área.

O ano de fabricação pode ser pego dos dois primeiros dígitos do número de série.

Certificado	DEKRA 23.0009 X
Marcas	Ex ec [ic] IIC T4..T6 Gc Ex ic IIC T4..T6 Gc Ex ic IIIC Dc
Normas	<b>ABNT NBR IEC 60079-0:2020 Versão Corrigida:2023</b> <b>ABNT NBR IEC 60079-7:2018 Versão Corrigida:2022</b> <b>ABNT NBR IEC 60079-11:2013 Versão Corrigida:2017</b>

Terminais 3,4,5,6	Terminais 1,2	Terminais 1,2	Terminais 1,2
Ex ic IIC, Ex ic IIIC	Ex ic IIC, Ex ic IIIC	Ex ic IIC, Ex ic IIIC	Ex ec
Uo: 9,6 V Io: 25 mA Po: 60 mW Lo: 33 mH Co: 2,4 µF	Ui = 35 V Ii = 110 mA Ci = 1 nF Li = 10 µH	Ui = 24 V Ii = 260 mA Ci = 1 nF Li = 10 µH	Umax ≤ 35 Vdc or Umax ≤ 24 Vdc

Ex ic IIC, Ex ic IIIC Classe de temperatura	Faixa de temperatura ambiente	
	Ui=35V	Ui=24V
<b>T6</b>	-40 °C to +54 °C	-40 °C to +63 °C
<b>T5</b>	-40 °C to +69 °C	-40 °C to +78 °C
<b>T4</b>	-40 °C to +85 °C	-40 °C to +85 °C

Ex ec Classe de temperatura	Faixa de temperatura ambiente	
	Umax=35V	Umax=24V
<b>T6</b>	-40 °C to +43 °C	-40 °C to +55 °C
<b>T5</b>	-40 °C to +85 °C	-40 °C to +85 °C
<b>T4</b>	-40 °C to +85 °C	-40 °C to +85 °C

**Notas de Instalação.**

Se o invólucro for feito de materiais plásticos não metálicos, devem ser evitadas cargas eletrostáticas no invólucro do transmissor.

Se o transmissor for instalado em uma atmosfera explosiva que exija o uso de nível de proteção de equipamento Gc e aplicado no tipo de proteção Ex ic, o transmissor deverá ser montado em um gabinete que forneça um grau de proteção de pelo menos IP20 de acordo com ABNT NBR IEC 60529, e adequado à aplicação e instalado corretamente.

Se o transmissor for instalado em uma atmosfera explosiva que exija o uso de nível de proteção de equipamento Dc, o transmissor deverá ser montado em um invólucro certificado separadamente que forneça um grau de proteção de pelo menos IP5X de acordo com a ABNT NBR IEC 60079-0, e que seja adequado para o aplicativo e instalado corretamente. A temperatura da superfície do invólucro externo é +20 K acima da temperatura ambiente, determinada sem camada de poeira.  
Faixa de temperatura ambiente: -40 °C a +85 °C

Se o transmissor for instalado em uma atmosfera explosiva que exija o uso de nível de proteção de equipamento Gc e aplicado no tipo de proteção Ex ec, o transmissor deverá ser montado em um invólucro certificado separadamente que forneça um grau de proteção de pelo menos IP54 de acordo com conforme ABNT NBR IEC 60079-0, e que seja adequado à aplicação e instalado corretamente.

Se o transmissor for instalado em uma atmosfera explosiva que exija o uso de nível de proteção de equipamento Gc e aplicado no tipo de proteção Ex ec, o equipamento deverá ser usado somente em uma área com grau de poluição não superior a 2, conforme definido na IEC 60664-1.

## Desenho de Instalação INMETRO



Para instalação segura do 5332D o seguinte deve ser observado. O modelo deve apenas ser instalado por pessoas qualificadas que são familiarizadas com as leis nacionais e internacionais, diretrizes e padrões que se aplicam a esta área.

O ano de fabricação pode ser pego dos dois primeiros dígitos do número de série.

Certificado .....DEKRA 23.0009 X

Marcas  
Ex ia IIC T6...T4 Ga  
Ex ia IIIC Db  
Ex ia I Ma

Normas  
**ABNT NBR IEC 60079-0:2020 Versão Corrigida:2023**  
**ABNT NBR IEC 60079-11:2013 Versão Corrigida:2017**

Áreas classificadas  
Zona 0, 1, 2, 21, 22,

Área não classificada

### Terminais 3,4,5,6

Uo: 9,6 VDC  
Io: 25 mA  
Po: 60 mW  
Lo: 33 mH  
Co: 2,4µF

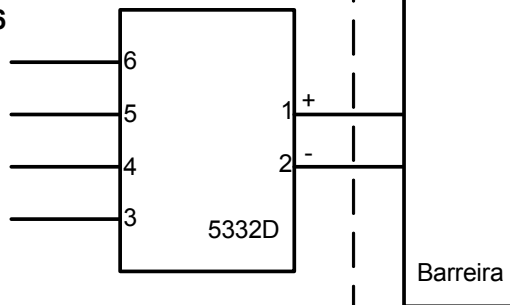

### Terminais: 1,2

Ui: 30 VDC  
Ii: 120 mA  
Pi: 0,84 W or 0,75W  
Li: 10µH  
Ci: 1,0nF

Classe de temperatura	Faixa de temperatura ambiente	
	Pi: 0,84W	Pi: 0,75W
<b>T6</b>	-40 °C to +47 °C	-40 °C to +50 °C
<b>T5</b>	-40 °C to +62 °C	-40 °C to +65 °C
<b>T4</b>	-40 °C to +85 °C	-40 °C to +85 °C

**Notas de instalação**

Se o invólucro for feito de materiais plásticos não metálicos, devem ser evitadas cargas eletrostáticas no invólucro do transmissor.

Se o transmissor for instalado em uma atmosfera explosiva que exija o uso de nível de proteção de equipamento Ga, o transmissor deverá ser montado em um invólucro que forneça um grau de proteção de pelo menos IP20 de acordo com a ABNT NBR IEC 60529, e que seja adequado para a aplicação e corretamente instalado.

Se o transmissor for instalado em uma atmosfera explosiva que exija o uso de equipamento de nível de proteção Ga ou Ma, e se o invólucro for feito de alumínio, ele deverá ser instalado de forma que fontes de ignição devido a faíscas de impacto e fricção sejam excluídas.

Se o transmissor for instalado em uma atmosfera explosiva que exija o uso de nível de proteção de equipamento Db, o transmissor deverá ser montado em um invólucro certificado separadamente que forneça um grau de proteção de pelo menos IP5X de acordo com a ABNT NBR IEC 60079-0, e que seja adequado para o aplicativo e instalado corretamente. A temperatura da superfície do invólucro externo é +20 K acima da temperatura ambiente, determinada sem camada de poeira. Faixa de temperatura ambiente: -40 °C a +85 °C

Se o transmissor for instalado em uma atmosfera explosiva que exija o uso de nível de proteção de equipamento Ma, o transmissor deverá ser montado em um invólucro que forneça um grau de proteção de pelo menos IP54 de acordo com a ABNT NBR IEC 60529, e que seja adequado para a aplicação e corretamente instalado. Faixa de temperatura ambiente: -40 °C a +85 °C

Devem ser utilizadas entradas de cabos e elementos de obturação adequados à aplicação e instalados corretamente.

Para uma temperatura ambiente  $\geq 60^{\circ}\text{C}$ , devem ser utilizados cabos resistentes ao calor com uma classificação de pelo menos 20 K acima da temperatura ambiente.

## Document history

The following list provides notes concerning revisions of this document.

<b>Rev. ID</b>	<b>Date</b>	<b>Notes</b>
100	1845	Initial release of the product.
101	2007	EAC, EAC Ex and INMETRO approvals added. CSA installation drawing for 5332A added.
102	2145	ATEX and IECEx approvals updated - Ex na changed to Ex ec.
103	2202	CSA installation drawings updated.
104	2245	UKCA added.
105	2411	INMETRO approval updated - Ex nA replaced by Ex ec.
106	2503	New EAC Ex certificate.

# We are near you, *all over the world*

**Our trusted red boxes are supported wherever you are**

All our devices are backed by expert service and a 5-year warranty. With each product you purchase, you receive personal technical support and guidance, day-to-day delivery, repair without charge within the warranty period and easily accessible documentation.

We are headquartered in Denmark, and have offices and authorized partners the world over. We are a local

business with a global reach. This means that we are always nearby and know your local markets well. We are committed to your satisfaction and provide PERFORMANCE MADE SMARTER all around the world.

For more information on our warranty program, or to meet with a sales representative in your region, visit [prelectronics.com](http://prelectronics.com).

# Benefit today from *PERFORMANCE MADE SMARTER*

PR electronics is the leading technology company specialized in making industrial process control safer, more reliable and more efficient. Since 1974, we have been dedicated to perfecting our core competence of innovating high precision technology with low power consumption. This dedication continues to set new standards for products communicating, monitoring and connecting our customers' process measurement points to their process control systems.

Our innovative, patented technologies are derived from our extensive R&D facilities and from having a great understanding of our customers' needs and processes. We are guided by principles of simplicity, focus, courage and excellence, enabling some of the world's greatest companies to achieve PERFORMANCE MADE SMARTER.