

# DUAL TRIP AMPLIFIER



- 2 adjustable alarm levels
- 300 VA relay contacts
- Programmable input
- Programmable relay functions
- 24 VDC supply
- For mounting in 11-pole relay socket



## Applications:

Alarm detector or controller in connection with DC current or voltage signals.

## Technical characteristics:

Current or voltage as standard signals.  
 Programmable via internal DIP-switches.  
 All signals are referred to supply ground.  
 Standard input voltage: See table  
 Input resistance: Typ. 10 M $\Omega$   
 Standard input current: See table  
 Input resistance: Nom. 50  $\Omega$ .  
 Special input signals according to order. (see common specifications).

## Setpoint:

Potentiometers for alarm level adjustment are front panel mounted and covers the entire input range (scale 0...100%). The alarm detector has relay outputs with two uncommitted change-over contacts available. The relays may be programmed to activate on a decreasing or an increasing input signal.  
 By increasing function the hysteresis is below the setpoint, by decreasing above.  
 The programming options include a 'hold'-function where relay 2 latches when the upper alarm level is reached. Furthermore, a 'failsafe'-function may be selected, where the relays are deactivated on decreasing relay function, when the input signal is < 2% of the measurement range. LEDs in the cassette front plate indicate activated relays.

## Electrical specifications:

### Specifications range:

-20°C to +60°C

### Common specifications:

Supply voltage.....	19.2...28.8 VDC
Internal consumption.....	1.2 W (relays ON)
Isolation test / operation.....	1.4 kVAC / 150 VAC
Scale accuracy .....	Better than 5%
Repetition accuracy .....	Better than 0.5%
Hysteresis.....	1% standard
Response time .....	Typ. 80 ms
Temperature coefficient.....	< $\pm 0.01\%$ of span / °C
EMC immunity influence .....	< 1%
Relative humidity .....	< 95% RH (non-cond.)
Dimensions (HxWxD).....	80.5 x 35.5 x 84.5 mm
Protection degree.....	IP50
Weight .....	125 g

### Input:

Max. measurement range.....	50 mA / 24 VDC
Min. measurement range (span).....	0.8 mA / 800 mVDC
Max. offset.....	20% of selected max. value
Input resistance, current.....	50 $\Omega$
Input resistance, voltage .....	Nom. 10 M $\Omega$

### Output:

Relay output:	
Max. voltage.....	150 VRMS
Max. current .....	2 A / AC
Max. AC power.....	300 VA
Max. load at 24 VDC .....	1 A

### GOST R approval:

VNIIM, Cert. no..... See [www.prelectronics.com](http://www.prelectronics.com)

<b>Observed authority requirements:</b>	<b>Standard:</b>
EMC 2004/108/EC .....	EN 61326-1
LVD 2006/95/EC .....	EN 61010-1

**Of span** = Of the presently selected range

Order: 2238

Type	Input	Output	Setpoint
2238	0...20 mA : A	2 x active at increasing input : 1	Setp. notch opr. : A
	4...20 mA : B	2 x active at decreasing input : 2	Setp. knob opr. : B
	0...1 V : C	Active at decreasing input 1 : 3	
	0.2...1 V : D	+ at increasing input 2	
	0...10 V : E	Active at decreasing input 2 : 4	
	Spec. : X	+ at increasing input 1	
		Hold rel. 2 : 5	

**Block diagram:**

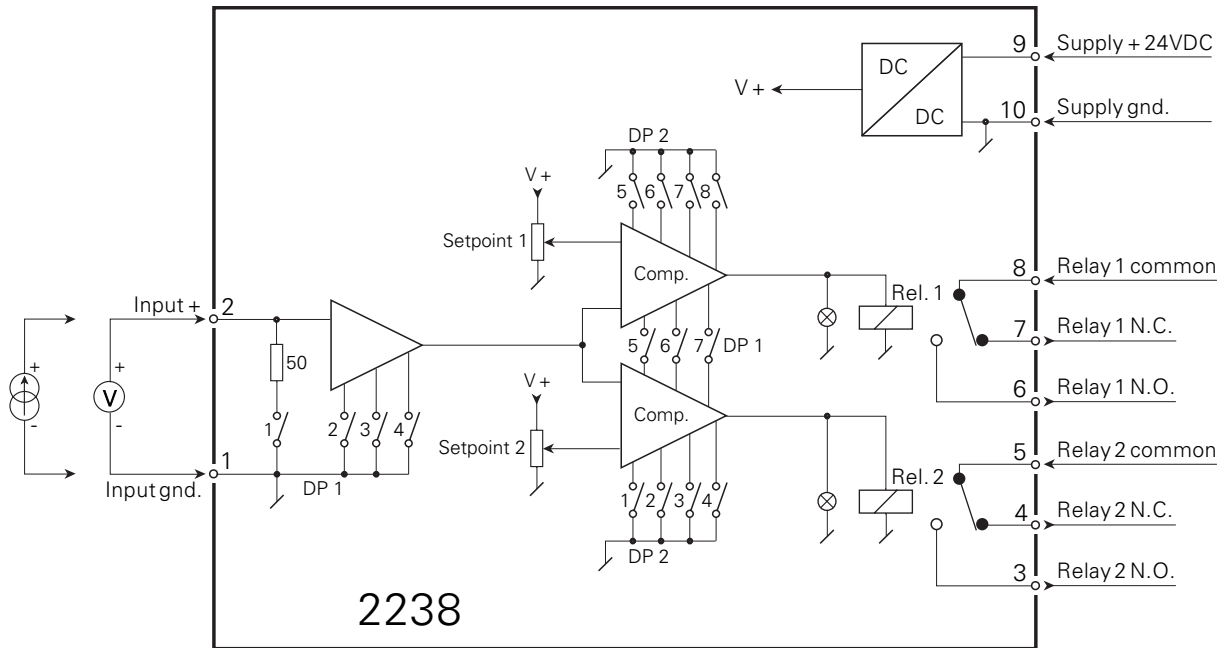

**Front layout:**

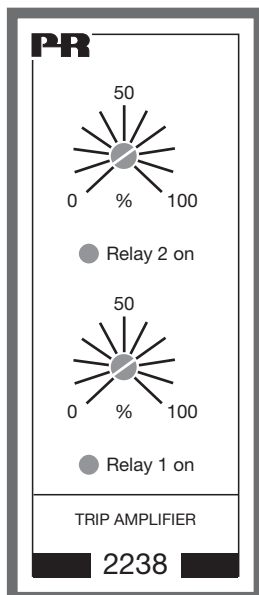

**Programming:**

Input and function	DP1 ON	DP2 ON
0...20 mA	1, 2	
4...20 mA	1, 3	
0...1 V	2	
0.2...1 V	3	
0...10 V	2, 4	
2...10 V	3, 4	
<u>Active relay 1 at:</u>		
Increasing input signal		5, 7
Decreasing input signal		6, 8
<u>Active relay 2 at:</u>		
Increasing input signal		1, 3
Decreasing input signal		2, 4
Relay 2 hold	5	
Relay 1 failsafe	7	
Relay 2 failsafe	6	

For safe operation, all other switches must be OFF.