

ISOLATION AMPLIFIER



- Galvanically separated input, output, and supply
- Bipolar current / voltage input
- Signal conversion
- Current and voltage output
- 24 VDC or universally supplied
- Applicable in PELV/SELV circuits



Application:

Galvanic separation of analogue signals (ground loop elimination). ● Measurement of floating signals. ● Signal conversion within the ranges: -250...+250 VDC or -50...+50 mA on the input and 0...10 (20) VDC and 0...20 mA on the output.

Description:

The 2284 uses microprocessor technology for the selection of gain and zero offset, yet the signal processing is analogue with a fast response time of less than 25 ms.

Technical characteristics:

In standard ranges, the 2284 is programmable within the input and output ranges using internal DIP-switches. Provided that the front adjustments are still sealed, the unit needs no re-adjustment after programming. The unit is galvanically separated between input, supply, and output.

Input:

Current or voltage in standard or special ranges within the measurement range. The programming schedule shows the standard ranges. Nominal standard input resistance is 50 Ω for mA signals. The 2284 has a 2-wire transmitter supply and a reference voltage of 2.5 VDC, max. 15 mA for short circuit-protected supply of potentiometers.

Output:

The output can be ordered for standard or special currents and voltages within the signal range.

Standard current output (pin 3) 0/4...20 mA, and 0/1...5 mA acc. to the programming schedule with the possibility of signal reversal. Current limit: 23...28 mA.

Standard voltage output (pin 2) is achieved by short-circuiting pins 2 and 3.

The voltage signal is available between pins 2 and 1.

For voltage signals in the ranges 0...1 VDC, a 50 Ω shunt (DP 2-1) is applied; in the ranges 0...10 VDC, a 500 Ω shunt (DP 2-2) is applied.

Using both signals simultaneously, the mA-loop to ground must go through the internal shunt.

The 2284 is available with a buffered voltage output, 0...20 V, 10 mA. The current output cannot be used simultaneously. In applications where the output must sink current, the following min. voltages on the output can be achieved: At 100 μ A; 10 mV, and at 1 mA; 90 mV.

Fine adjustment of 0 and 100% values for special ranges is possible at the front \pm 2.5%, but please note that the basic calibration is thereby lost.

Electrical specifications:

Specifications range..... -20°C to +60°C

Common specifications:

Supply voltage, DC 19.2...28.8 VDC
 Universal supply voltage 21.6...253 VAC, 50...60 Hz
 19.2...300 VDC

Max. consumption 2284--D, (24 VDC) \leq 2.4 W
 Max. consumption 2284--P (uni. sup.) \leq 2.5 W
 Isolation, test / operation..... 3.75 kVAC / 250 VAC
 Signal / noise ratio..... Min. 60 dB
 Response time (0...90%) < 25 ms
 Temperature coefficient < \pm 0.01% of span / °C
 Linearity error < \pm 0.1% of span
 Effect of supply voltage change < \pm 0.005% of span / V
 2-wire transmitter supply (pin 7...5)... 19...28 VDC / 20...0 mA
 Reference voltage 2.5 VDC \pm 0.5%, 15 mA
 EMC immunity influence < \pm 0.5% of span
 Humidity < 95% RH (non-cond.)
 Dimensions (HxWxD) (D is without pins) 80.5 x 35.5 x 84.5 mm
 Protection degree IP50
 Weight DC / universally supplied..... 125 g / 165 g

Input:

Measurement range -50...+50 mADC
 Min. measurement range (span)..... 0.53 mADC
 Max. offset..... 50% of max. value
 Input resistance Nom. 50 Ω

Voltage:

Measurement range -250...+250 VDC
 Min. measurement range (span)..... 27 mVDC
 Max. offset..... 50% of max. value
 Input resistance >1 M Ω ...<10 M Ω

Current output:

Signal range / min. signal range 0...20 mA / 4 mA
 Max. offset..... 20% of max. value
 Load (max.)..... 20 mA/ 1000 Ω / 20 VDC
 Load stability < \pm 0.01% of span / 100 Ω
 Current limit..... 23...28 mA

Voltage output through internal shunt:

Signal range / min. signal range 0...10 VDC / 200 mVDC
 Max. offset..... 20% of max. value
 Load (min.)..... 500 k Ω
 Buffered voltage Min. 0.2...1 VDC/max. 0...20 VDC
 Max. load..... 10 mA

GOST R approval:

VNIIM, Cert. no. Ross DK.ME48.V01899

Observed authority requirements: Standard:

EMC 2004/108/EC
 Emission and immunity EN 61326-1
 LVD 2006/95/EC EN 61010-1
 PELV/SELV..... IEC 364-4-41 and EN 60742

Of span = Of the presently selected range

Order: 2284

Type	Input	Output	Supply	Output type
2284	0...20 mA : A	Special : 0	24 VDC : D	Standard : 1
	4...20 mA : B	0...20 mA : 1	24...230 VAC & : P	Buffered voltage : 2
	0...1 V : C	4...20 mA : 2	24...250 VDC	
	0.2...1 V : D	0...5 mA : 3		
	0...10 V : E	0...1 V : 4		
	2...10 V : F	0.2...1 V : 5		
	0...2.5 V : G	0...10 V : 6		
	-10...+10 V : H	2...10 V : 7		
	Special : X	0...2.5 V : 8		

Block diagram:

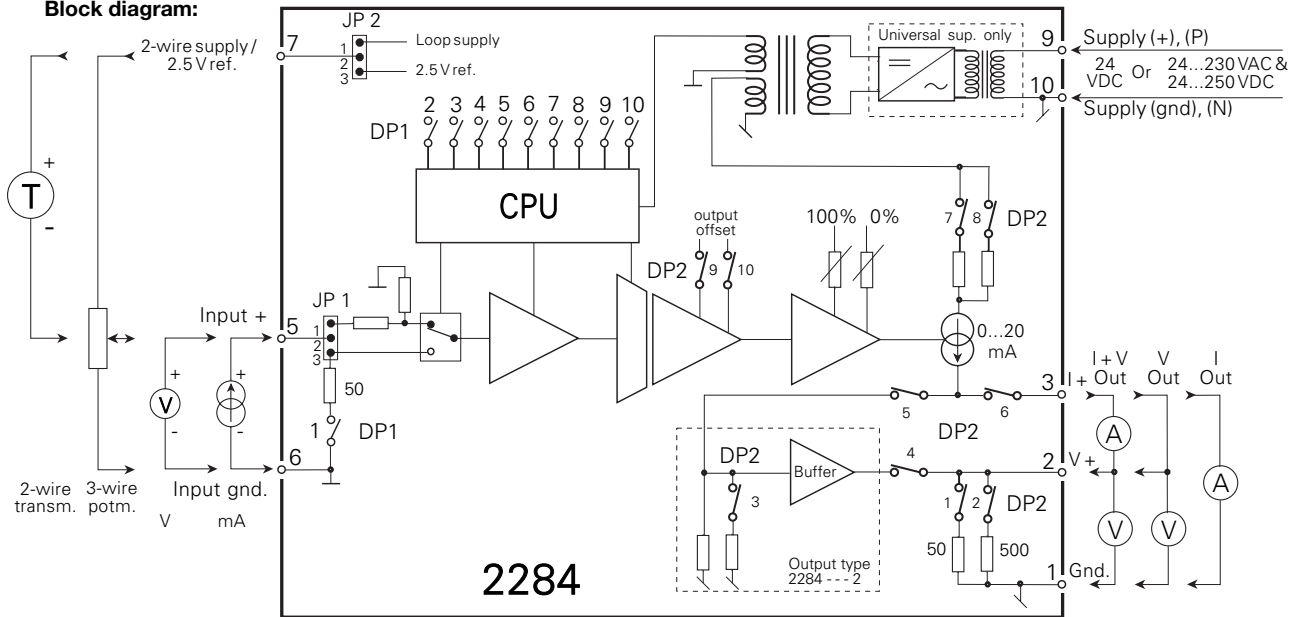

INPUT PROGRAMMING	DP1 (10-pole) SW 1, 2, 3, 4, 5, 6		JP1 POSITION	
	SW ON	SW OFF	1 - 2	2 - 3
0...5 mA	1, 2, 3	4, 5, 6		X
0...20 mA	1, 2, 3, 4	5, 6		X
0...100 mV	-	1, 2, 3, 4, 5, 6		X
0...500 mV	4	1, 2, 3, 5, 6		x
0...1 V	3	1, 2, 4, 5, 6		X
0...2.5 V	3, 4	1, 2, 5, 6		X
0...10 V	2	1, 3, 4, 5, 6	X	
0...100 V	2, 4	1, 3, 5, 6	X	
For 20% offset on input, set DP1 SW5 ON e.g. input 4...20 mA	1, 2, 3, 4, 5	6		X
For bipolar input set DP1, SW6 ON e.g. -10 V...+10 V	2, 6	1, 3, 4, 5	X	

** DP2 SW 6 is ON and SW 3, 4, 5 are OFF, except for buffered output 2284---2.

Note: At other spans than the ones mentioned in the table and at a buffered voltage output, DP1, DP2, JP1, and JP2 have a different setting which applies to the delivered special range.

The buffered voltage output cannot be programmed acc. to the above programming table, but will be delivered fully-configured from factory.

OUTPUT PROGRAMMING	DP1 (10-pole) SW 7, 8, 9, 10		** DP2 (10-pole) SW 1, 2, 7, 8, 9, 10	
	SW ON	SW OFF	ON	OFF
0...5 mA	8	7, 9, 10	6, 7	1, 2, 8, 9, 10
0...20 mA	7	8, 9, 10	6, 8	1, 2, 7, 9, 10
0...5 mA / 0...250 mV	8	7, 9, 10	1, 6, 7	2, 8, 9, 10
0...20 mA / 0...1 V	7	8, 9, 10	1, 6, 8	2, 7, 9, 10
0...5 mA / 0...2.5 V	8	7, 9, 10	2, 6, 7	1, 8, 9, 10
0...20 mA / 0...10 V	7	8, 9, 10	2, 6, 8	1, 7, 9, 10
For 20% offset on output, set DP1 SW9 ON, DP2 SW9 and SW10 ON, e.g. output 4...20 mA	7, 9	8, 10	6, 8, 9, 10	1, 2, 7
For reversed output set DP1, SW10 ON e.g. output 20...4 mA	7, 9, 10	8	6, 8, 9, 10	1, 2, 7