

# SIGNAL CALCULATOR



- Two analogue inputs
- Multiple functions
- Front-programmable
- 3-digit LED display
- Version with a Pt100 input
- Analogue output



## Application:

Operates as a PID controller with an analogue or a Pt100 input, a manual / automatic controller, an analogue calculator with a scale function on both inputs, a sample-hold transmitter, a peak-hold transmitter, a delay transmitter, a signal limiter, averaging of noisy signals, monitoring of a signal's slope, or an analogue multiplexer. • The 2289 Signal Calculator will meet the demands of any process engineer with an unexpected or special signal processing assignment at hand.

## Technical characteristics:

The unit is built around a microprocessor core with an efficient program operation. The basic calibration data and the present set-up are saved in an EEPROM thereby avoiding the loss or change of data at power off. The user interface consists of a 3-digit display and 3 front function keys. The input and output values, function, and all parameter selections are entered by means of the user interface. Both the input signals and the output signal can be inverted.

## Functions:

### Analogue calculator:

Contains the following calculation functions: addition, subtraction, maximum / minimum selection, multiplication, division, raising to a power and root extraction. At raising to a power and root extraction, any of the analogue inputs can be selected. By means of the scale function the calculation functions can be executed on differently scaled input signals.

### Sample-Hold:

Activation of the digital input (hold) will set the output value to the present input value and will hold this value for as long as the digital input is active. At a deactivated digital input the output value will track the input value.

### Peak-Hold:

At a deactivated digital input the output value is the greatest input value registered since the last reset. Activation of the digital input will set the output value at the present input value (reset).

### Delay:

The delay function transfers the input value to the output according to an exponential curve (R/C delay), where the time constant of the R/C delay can be entered.

### PID controller:

Features the following regulation parameters: XP (proportional band), TI (integrating time), and TD (differentiating time). The units are selected as XP %, TI s, and TD s. By selecting TI and TD as 0, the function will be a pure proportional controller. The regulation can be either direct or inverted. The setpoint can be selected as an internal or external current / voltage signal.

## Manual / automatic controller:

The digital input is used to change between the manual and automatic mode. In the automatic mode the analogue output follows input A. When changing to the manual mode the analogue output is fixed and can now be activated up or down manually. The output holds the manual setting for an unlimited period.

## Signal limiter:

By the signal limiting function the output follows the input values linearly in the range between the min. and max. settings. At input signals outside the min. and max. settings, the output is fixed on either the min. or the max. value. The min. or the max. value can be set externally by means of the other analogue input.

## Averaging transmitter:

The averaging function calculates an accurate average value of the input values over a set period. Once this period has expired the output will be updated by the average value. This means that the output will typically make a jump at each update. A stack function can be selected to increase the updates of the output and to decrease any jumps while still keeping the set averaging period.

## Slope transmitter (dl/dt function):

The dl/dt function converts the slope of the input over a set period to an analogue output signal. The min. and max. slope to be converted are entered in % of the input span. The slope can be selected as either positive or negative. By means of a pressure transmitter the dl/dt function is suitable for e.g. leak monitoring or flow measurement of substances with a high viscosity grade.

## Analogue multiplexer:

At a deactivated digital input, input A x P1 is sent to the output. At an activated digital input, input B x P2 is sent to the output. P1 and P2 are scaling factors for the two inputs.

## Inputs:

### Analogue inputs - 2289A

The A and B inputs can be programmed according to your choice to receive current signals in the range 0...20 mA (for instance 4...20 mA), or voltage signals in the range 0...10 VDC.

### Pt100 input - 2289B

Input A is a linearised Pt100 temperature input in the range -99...+850°C with a 3-wire connection. The measurement range can be scaled via the front keys acc. to your choice. As 2289A, input B is an analogue current / voltage input.

### Digital input - 2289A

By way of JP6 the 2289 signal calculator can be programmed to NPN (pull up to 24 VDC), or PNP (pull down to 0 VDC). Min. pulse length is 50 ms.

## Output:

Analogue standard current / voltage output of 0/4...20 mA / 0/2...10 VDC. The output span can be set to special current / voltage signals acc. to your choice. Max. load on the current output is 600 Ω. Min. load on the voltage output is 500 kΩ.

**Electrical specifications:****Specifications range:**

-20 to +60°C

**Common specifications:**

Supply voltage.....	19.2...28.8 VDC
Internal consumption.....	2.4 W
Max. consumption.....	2.7 W
Signal / noise ratio.....	Min. 60 dB
Signal dynamics, input.....	20 bit
Signal dynamics, output.....	16 bit
Proportional band (XP).....	0.01...999%
Gain.....	0.1...10000
Integrating time (TI).....	0...999 s
Differentiating time (TD).....	0...999 s
Response time.....	< 60 ms
Updating time.....	20 ms
Calibration temperature.....	20...28°C
Temperature coefficient.....	< ±0.01% of span/°C
Linearity error.....	< ±0.1% of span
Effect of supply voltage change.....	< ±0.002% of span/%V
Auxiliary voltages:	
Reference voltage.....	2.5 VDC ±0.5% / 15 mA
EMC immunity influence.....	< ±0.5%
Relative air humidity.....	< 95% RH (non-cond.)
Dimensions (HxWxD) (D is excl. pins) ..	80.5 x 35.5 x 84.5 mm
Protection degree.....	IP50
Weight.....	130 g

**Electrical specifications - INPUT:****Current input:**

Measurement range.....	0...20 mA
Min. measurement range (span).....	4 mA
Max. offset.....	50% of selec. max. value
Input resistance.....	Nom. 50 Ω

**Voltage input:**

Measurement range.....	0...10 VDC
Min. measurement range (span).....	200 mV
Max. offset.....	50% of selec. max. value
Input resistance.....	Nom. 10 MΩ

**Digital input:**

NPN.....	Pull up 24 VDC / 6.9 mA
PNP.....	Pull down 0 VDC/6.9 mA
Pulse length.....	> 50 ms

**Pt100 input 2289B:**

Measurement range.....	-99...+850°C
Min. measurement range (span).....	50°C
Max. offset.....	50% of selec. max. value
Cable resistance per wire (max.).....	25 Ω
Sensor current.....	Nom. 1.25 mA
Response time.....	< 100 ms
Basic accuracy.....	< ±0.2°C
Temperature coefficient:	
span < 100°C.....	< ±0.01°C/°Camb.
span > 100°C.....	< ±0.01% of span/°Camb.
Immunity influence:	
span < 100°C.....	< ±1% of span
span > 100°C.....	< ±0.5% of span
Effect of sensor cable resistance.....	< 0.002 Ω/Ω

**Electrical specifications - OUTPUT:****Current output:**

Signal range.....	0...20 mA
Min. signal range (span).....	5 mA
Max. offset.....	50% of selec. max. value
Load (max.).....	20 mA / 600 Ω / 12 VDC
Load stability.....	< ±0.01% of span/100 Ω
Current limit.....	20.5 mA

**Voltage output via internal shunt:**

Signal range.....	0...10 VDC
Min. signal range (span).....	250 mV
Max. offset.....	50% of selec. max. value
Load (min.).....	500 kΩ
Voltage limit.....	10.25 VDC

**GOST R approval:**

VNIIM, Cert. no..... Ross DK.ME48.V01899

**Observed authority requirements: Standard:**EMC 2004/108/EC  
Emission and immunity..... EN 61326**Of span** = Of the presently selected range

# Routing diagram

If no buttons are pressed for a period of 20 minutes, the display returns to default 0.0.

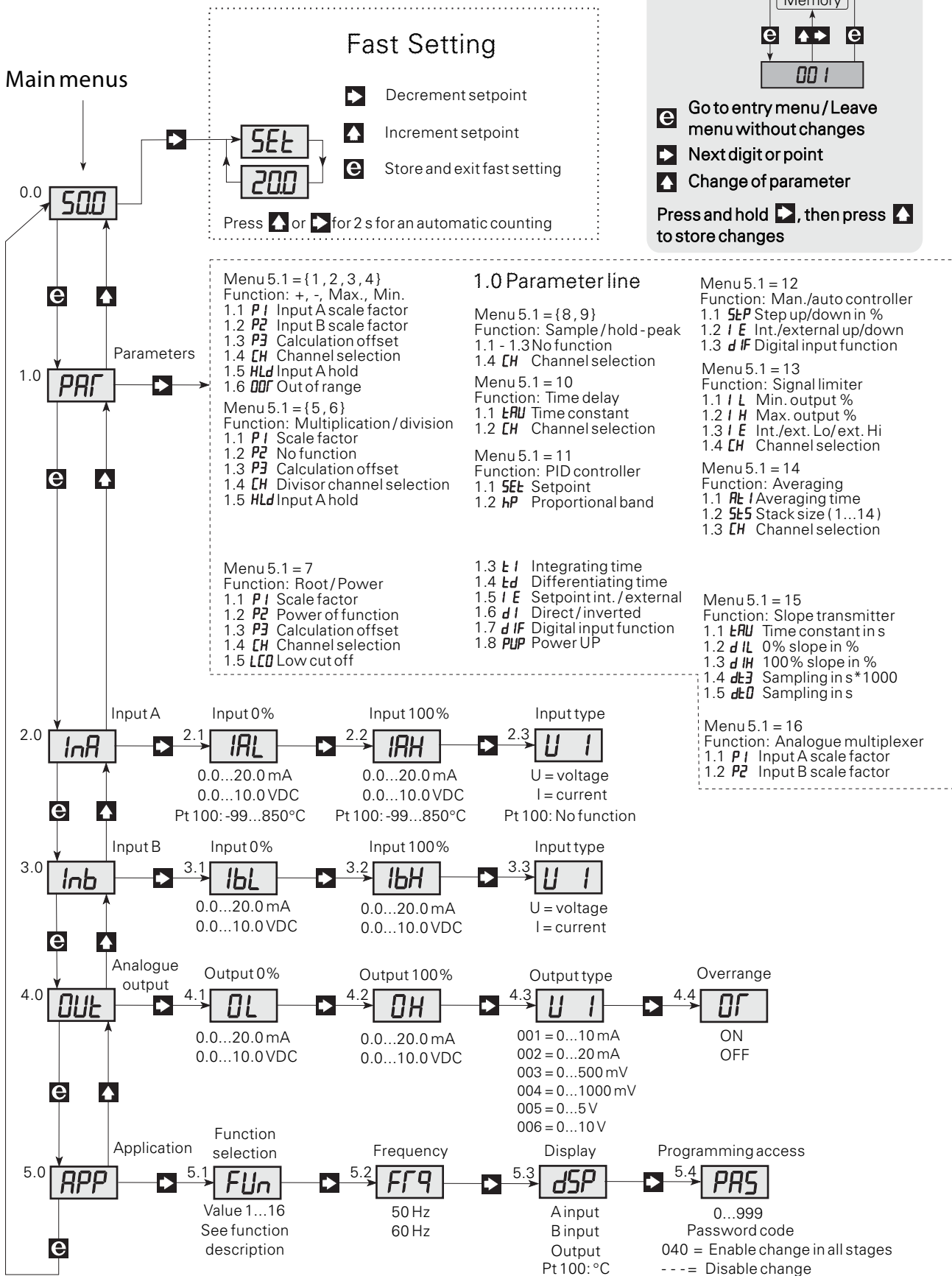

Type	Inputs
2289	Current / voltage : A Pt100 & current / voltage : B

**Block diagrams:**

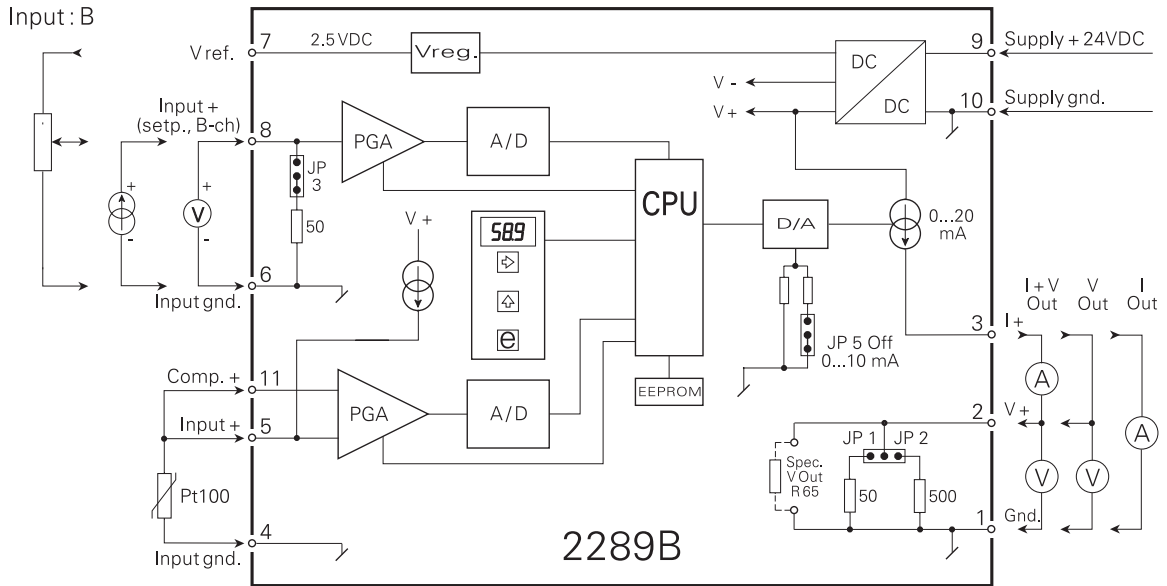
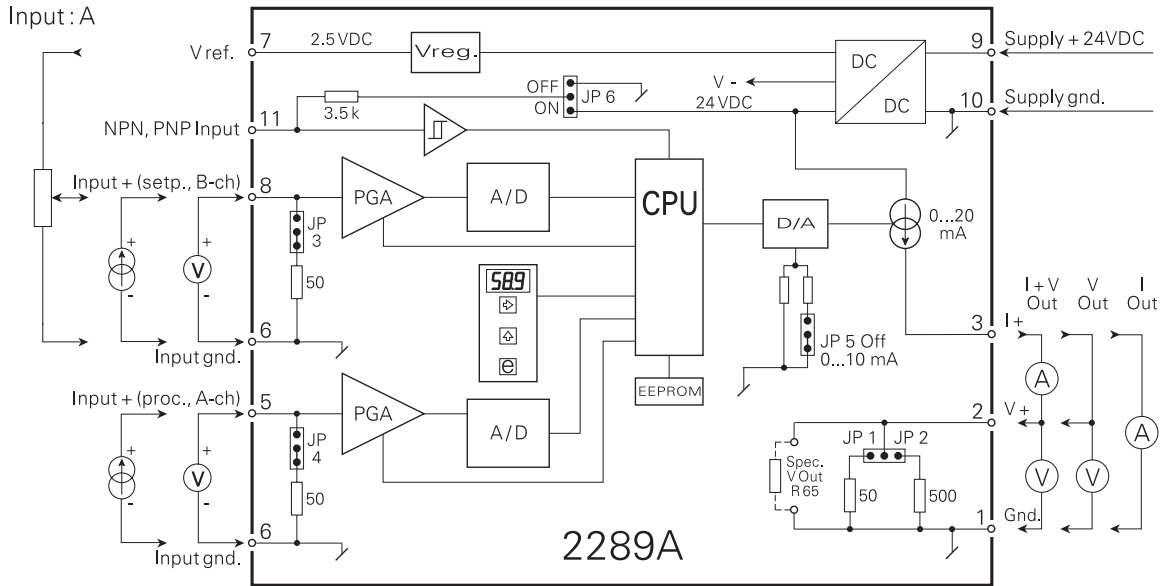

**Hardware programming:**

**INPUT:**

<b>Channel A</b> 0...20 mA 0...10 VDC	JP4	ON	MENU 2.3 = I
	JP4	OFF	MENU 2.3 = U
<b>Channel B</b> 0...20 mA 0...10 VDC	JP3	ON	MENU 3.3 = I
	JP3	OFF	MENU 3.3 = U
NPN PNP	JP6	ON	
	JP6	OFF	

**OUTPUT:**

Output	JP1	JP2	JP5	MENU 4.3
0...10 mA	OFF	OFF	OFF	1
0...20 mA	OFF	OFF	ON	2
0...500 mV	ON	OFF	OFF	3
0...1000 mV	ON	OFF	ON	4
0...5 V	OFF	ON	OFF	5
0...10 V	OFF	ON	ON	6