

2-WIRE ROOM TEMPERATURE TRANSMITTER



- Room temperature measurement
- Complete with sensor and transmitter
- 4...20 mA output in 2-wire connection
- Easy mounting
- Measurement range 0...70°C
- Supply 8...35 VDC



Application:

Electronic temperature measurement in for instance control rooms, offices, heating plants, factories, living rooms, and similar dry rooms. • Suitable as a transmitter for controllers, trip amplifiers, displays, or superior SCADA systems.

Technical characteristics:

The module is built around a microprocessor core with an efficient program operation. The basic calibration data and the present set-up are stored in an EEPROM thereby ensuring that the data is not lost or changed at power off. A precision Pt100 sensor with a small mass is mounted on the transmitter input thereby achieving a fast response time. The room temperature transmitter is protected against polarity reversal.

The front of the cabinet is made of white ABS plastics, the bottom is made of black PBT plastics. The bottom of the cabinet can be attached to a wall by two screws and the front is then clipped on to the bottom plate. Visible cable connection through a 10 mm cutout in the front of the cabinet. Covered cable connection through a 16 mm cutout in the bottom plate of the cabinet.

Input:

The input is mounted at the factory.

Output:

The 2-wire output signal of 4...20 mA is proportional and linear to the temperature value that influences the built-in sensor. The output signal represents the temperature range (span) to which the transmitter has been set up. A span of 0...50°C means that the output signal is 4 mA at 0°C and 20 mA at 50°C. The temperature range must be specified when ordering. A reversed output signal of 20...4 mA can be ordered. Also, a number of different sensor error detection methods are offered, for instance max. ≥ 23 mA.

Electrical specifications:

Specifications range:

0°C to +70°C

Common specifications:

Supply voltage.....	8.0...35 VDC
Internal consumption.....	25 mW...0.8 W
Voltage drop	8 VDC
Warm-up time.....	5 min.
Signal / noise ratio.....	Min. 60 dB
Response time	10 s (@ 0.5 m/s)
Signal dynamics, input	17 bit
Signal dynamics, output.....	16 bit
Calibration temperature.....	20...28°C
Temperature coefficient.....	< $\pm 0.01^\circ\text{C}/^\circ\text{C}_{\text{amb}}$
Linearity error	< $\pm 0.1\%$ of span
Effect of supply voltage change.....	$\leq \pm 0.005\%$ of span / VDC
EMC immunity influence	< $\pm 0.5\%$ of span
Max. wire size.....	1 x 1.5 mm ²
Humidity	< 95% RH (non-cond.)
Dimensions (H x B x D).....	70 x 121 x 25 mm
Protection degree.....	IP30
Weight	95 g

Input:

Measurement range	0...70°C
Min. measurement range (span).....	25°C
Max. offset.....	50% of max. °C
Sensor current.....	> 0.2 mA, < 0.4 mA
Basic accuracy.....	< $\pm 0.3^\circ\text{C}$

Output:

Signal range	4...20 mA
Min. signal range.....	16 mA
Max. offset.....	20% of max. mA
Updating time.....	135 ms
Load resistance	$\leq (V_{\text{supply}} - 8) / 0.023 [\Omega]$
Load stability	< $\pm 0.01\%$ of span/100 Ω

Sensor error detection:

Please order exact value	3.5...23 mA
NAMUR NE43 Upscale	23 mA
NAMUR NE43 Downscale.....	3.5 mA
To max.....	≥ 23 mA
To min.....	≤ 3.8 mA
No function.....	Not defined

GOST R approval:

VNIIM, Cert. no. Ross DK.ME34.V01899

Observed authority requirements: Standard:

EMC 2004/108/EC
Emission and immunity..... EN 61326-1

Of span = Of the presently selected range

Order: 2914

Type	Measurement range	Output	Sensor error value
2914	0...50°C : A	Special : 0	To max., ≥ 23 mA : A
	0...70°C : B	4...20 mA : 2	To min., ≤ 3.8 mA : B
	Special : X	20...4 mA : 9	Special : X

Block diagram:

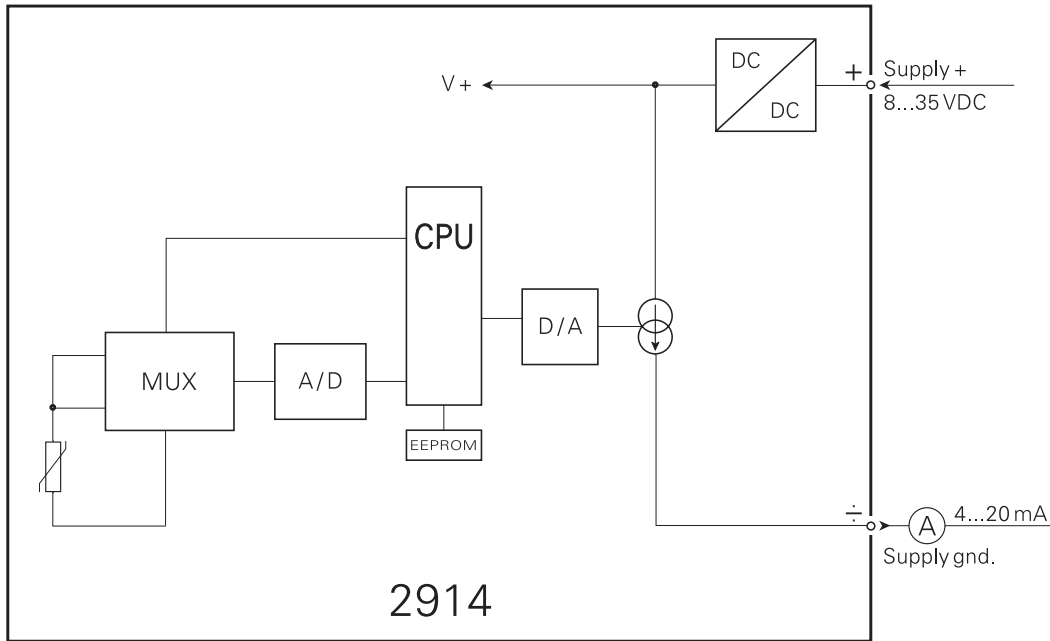

Mechanical specifications:

