

LOOP-POWERED ISOLATOR



- 1-, 2- and 4-channel galvanic isolation
- Slimline channel width of less than 6 mm
- No separate supply necessary
- Low response time
- High noise suppression



Application:

- Galvanic separation of analogue current signals.
- Elimination of ground loops and measurement of floating signals.
- A competitive choice in terms of both price and technology for galvanic isolation of current signals to SCADA systems or PLC equipment.
- Especially useful in applications necessitating an unproblematic transmission of current signals according to NAMUR (sensor error detection).

Technical characteristics:

- PR 6185 is powered by the measured signal and loads the loop with max. 1.8 VDC.
- The input is protected against overvoltage and polarity error.
- The drop voltage for each channel can be calculated according to the following expression: $V_{drop} = 1.8 + (I_{out} \cdot R_{load})$.
- The output is voltage-limited to 15 VDC.
- Inputs and outputs are floating and galvanically separated.

Mounting / installation:

- Mounted vertically or horizontally on a DIN rail. As the modules can be mounted without distance between neighbouring units, up to 168 channels can be mounted per metre.

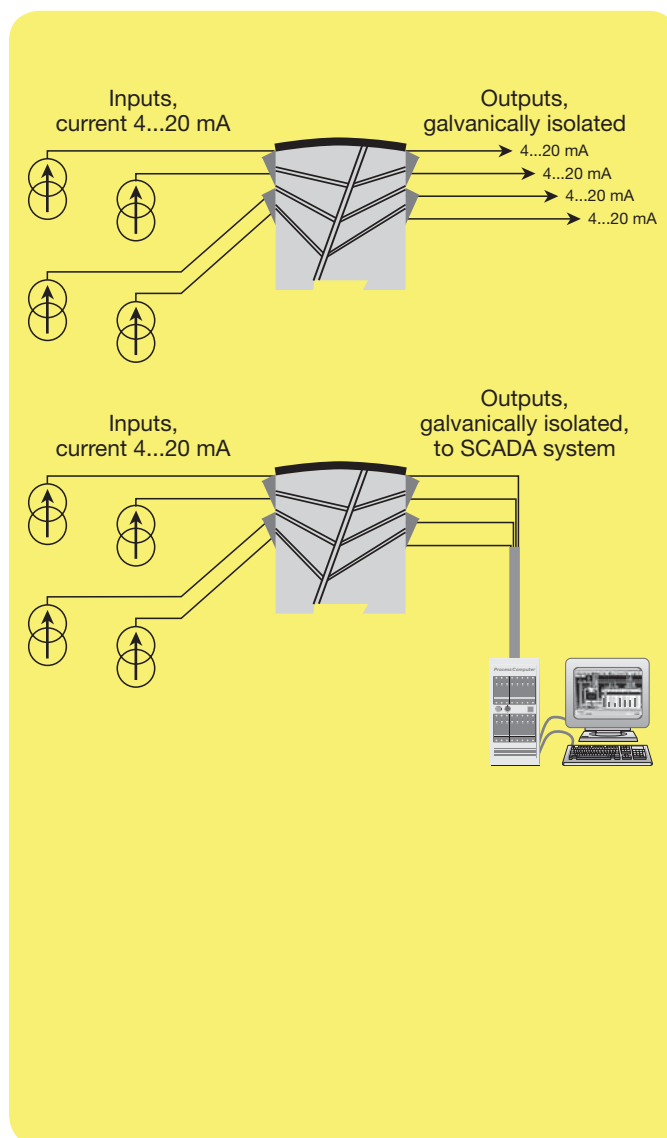

Order: 6185

Type	Channels
6185	1 channel : A
	2 channels : B
	4 channels : D

Connections:

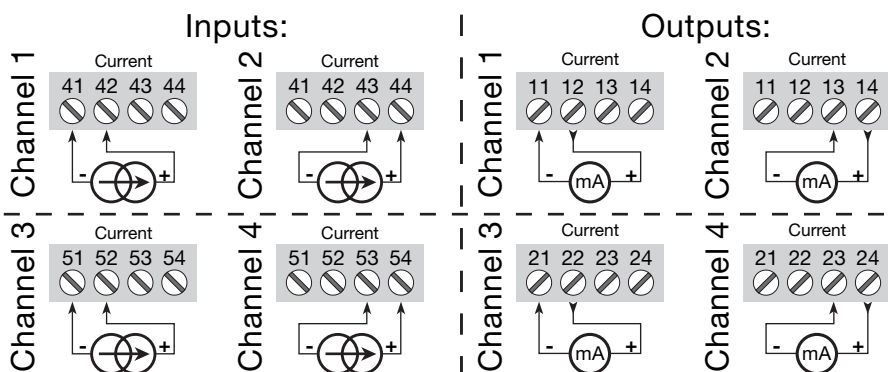

Electrical specifications:

Specifications range:

-20 to +60°C

Common specifications:

- Internal consumption, max..... 40 mW per channel
- Drop voltage, min.< 1.8 VDC
- Drop voltage, max. 1.8 V + (I_{out.} * R_{load})
- Isolation voltage, test 2 kVAC
- Signal / noise ratio..... > 60 dB (0...100 kHz)
- Response time (0...90%, 100...10%).. < 4 ms
- Calibration temperature..... 20...28°C
- Accuracy, the greater of general and basic values:

General values		
Input type	Absolute accuracy	Temperature coefficient
mA	≤ ±0.1% of span	≤ ±0.01% of span / °C

Basic values		
Input type	Basic accuracy	Temperature coefficient
mA	≤ ±16 µA	≤ ±1.6 µA/°C

- EMC immunity influence < ±0.5% of span
- Wire size (max.) 1 x 2.5 mm² stranded wire
- Screw terminal torsion..... 0.5 Nm
- Relative humidity < 95% RH (non cond.)
- Dimensions (HxWxD)..... 109 x 23.5 x 104 mm
- DIN rail type..... DIN 46277
- Protection degree..... IP20
- Weight 1 / 2 / 4 channels..... 155 / 180 / 230 g

Current input:

- Measurement range 0...23 mA
- Min. span..... 1:1
- Input resistance at 20 mA ≈ 90 Ω + R_{load}

Current output:

- Signal range (span)..... 0...23 mA
- Min. signal range 1:1
- Load (max.)..... 20 mA / 600 Ω / 12 VDC
- Load stability < 0.03% of span / 100 Ω
- Current limit..... 50 mA
- Voltage limit..... 15 VDC

GOST R approval:

VNIIM, Cert. No. See homepage

Observed authority requirements: Standard:

EMC 2004/108/EC EN 61326-1

Of span = of the presently selected range