

2-WIRE HART® TRANSMITTER

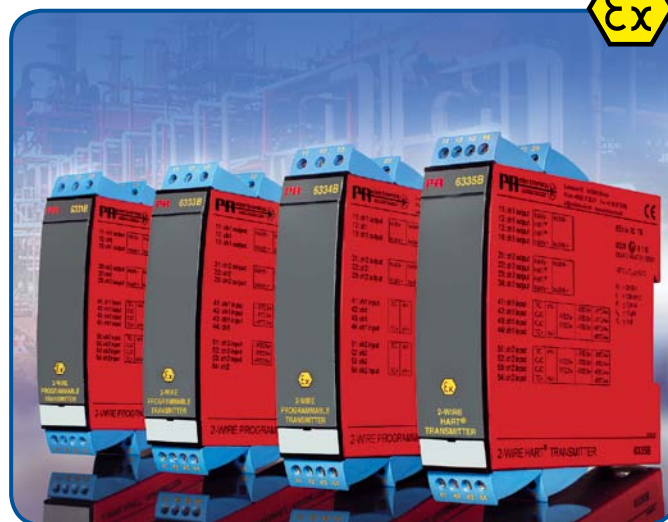

- RTD, TC, Ohm, or mV input
- Extremely high measurement accuracy
- HART® communication
- Can be installed in Ex zone 0
- 1- or 2-channel version



Application:

- Linearised temperature measurement with Pt100...Pt1000, Ni100...Ni1000, or TC sensor.
- Difference or average temperature measurement of 2 resistance or TC sensors.
- Conversion of linear resistance variation to a standard analogue current signal, for instance from valves or Ohmic level sensors.
- Amplification of a bipolar mV signal to a standard 4...20 mA current signal.
- Connection of up to 15 channels to a digital 2-wire signal with HART® communication.

Technical characteristics:

- Within a few seconds the user can program PR6335D to measure temperatures within all ranges defined by the norms.
- The RTD and resistance inputs have cable compensation for 2-, 3- and 4-wire connection.
- The 6335D has been designed according to strict safety requirements and is thus suitable for application in SIL 2 installations.
- Continuous check of vital stored data for safety reasons.
- Sensor error detection according to the guidelines in NAMUR NE 89.

Mounting / installation:

- Mounted vertically or horizontally on a DIN rail. As the modules can be mounted without any distance between neighbouring units, up to 84 channels can be mounted per metre.
- **NB:** As Ex barrier we recommend 5106B.

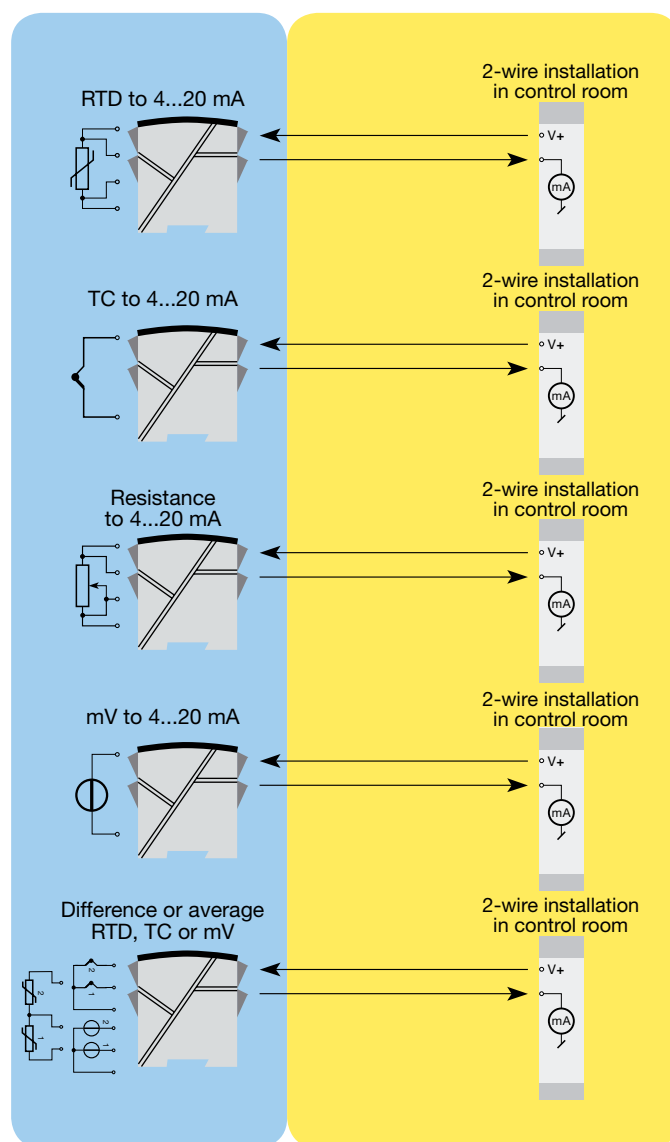

Order: 6335

Type	Version	Galvanic isolation	Channels
6335	CSA, FM & ATEX : D	1500 VAC : 2	Single : A Double : B

***NB!** Please remember to order CJC connectors type 5910Ex (channel 1) and 5913Ex (channel 2) for TC inputs with an internal CJC.

Connections:

All connection options are shown in the user manual.

Inputs:

Outputs:

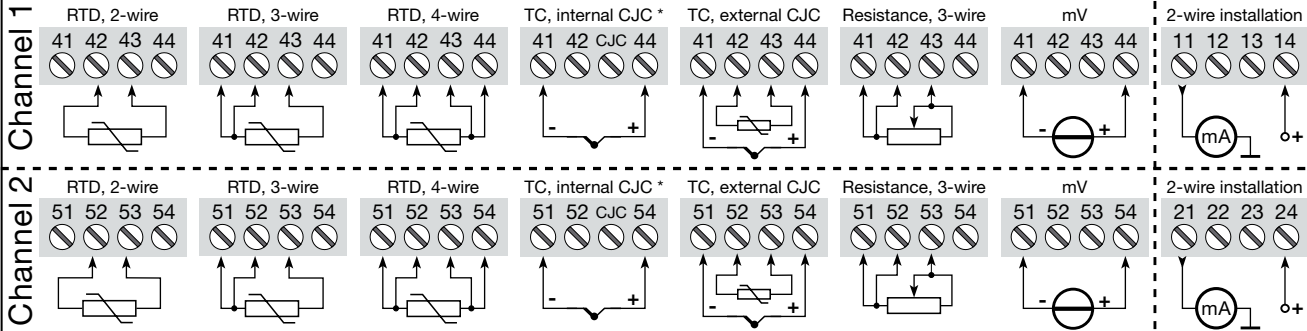

Electrical specifications:

Specifications range:

-40°C to +60°C

Common specifications:

Supply voltage..... 8.0...30 VDC
 Voltage drop..... 8.0 VDC
 Isolation voltage, test / operation..... 1.5 kVAC / 50 VAC
 Isolation voltage, ch. 1 / ch. 2..... 1500 VAC
 Communications interface..... Loop Link & HART®
 Signal / noise ratio..... Min. 60 dB
 Response time (programmable)..... 1...60 s
 Signal dynamics, input..... 22 bit
 Signal dynamics, output..... 16 bit
 Calibration temperature..... 20...28°C
 Accuracy, the greater of general and basic values:

TC input:

Type	Min. temperature	Max. temperature	Min. span	Standard
B	+400°C	+1820°C	100°C	IEC584
E	-100°C	+1000°C	50°C	IEC584
J	-100°C	+1200°C	50°C	IEC584
K	-180°C	+1372°C	50°C	IEC584
L	-100°C	+900°C	50°C	DIN 43710
N	-180°C	+1300°C	50°C	IEC584
R	-50°C	+1760°C	100°C	IEC584
S	-50°C	+1760°C	100°C	IEC584
T	-200°C	+400°C	50°C	IEC584
U	-200°C	+600°C	50°C	DIN 43710
W3	0°C	+2300°C	100°C	ASTM E988-90
W5	0°C	+2300°C	100°C	ASTM E988-90

General values		
Input type	Absolute accuracy	Temperature coefficient
All	≤ ±0.05% of span	≤ ±0.005% of span / °C

Basic values		
Input type	Basic accuracy	Temperature coefficient
Pt100 and Pt1000	≤ ±0.1°C	≤ ±0.005°C/°C
Ni100	≤ ±0.2°C	≤ ±0.005°C/°C
Lin. R	≤ ±0.1 Ω	≤ ±5 mΩ / °C
Volt	≤ ±10 μV	≤ ±0.5 μV / °C
TC type: E, J, K, L, N, T, U	≤ ±0.5°C	≤ ±0.025°C / °C
TC type: B, R, S, W3, W5	≤ ±1°C	≤ ±0.1°C / °C

EMC immunity influence.....	< ±0.1% of span
Extended EMC immunity: NAMUR NE 21, A criterion, burst.....	< ±1% of span

Humidity..... < 95% RH (non-cond.)
 Dimensions (H x W x D)..... 109 x 23.5 x 104 mm
 Protection degree..... IP20
 Weight (1 / 2 channels)..... 145 / 185 g

Electrical specifications, input:

Max. offset..... 50% of selec. max. value

RTD and linear resistance input:

RTD type	Min. value	Max. value	Min. span	Standard
Pt100	-200°C	+850°C	10°C	IEC 60751
Ni100	-60°C	+250°C	10°C	DIN 43760
Lin. R	0 Ω	7000 Ω	25 Ω	-----

Cable resistance per wire (max.)..... 5 Ω
 Sensor current..... Nom. 0.2 mA

Cold junction compensation..... < ±1.0°C

Voltage input:

Measurement range..... -800...+800 mV
 Min. span..... 2.5 mV
 Input resistance..... 10 MΩ

Current output:

Signal range..... 4...20 mA
 Min. signal range..... 16 mA
 Updating time..... 440 ms
 Load resistance..... ≤ (V_{supply} - 8) / 0.023 [Ω]

Sensor error detection:

Programmable..... 3.5...23 mA

Ex / I.S. approval:

KEMA 09ATEX0148..... II 1 G Ex ia IIC
 T6...T5

Applicable in zone..... 0, 1 or 2
 ATEX Installation Drawing No. 6335QA01

FM, applicable in..... IS, Cl. I, Div. 1, Gr. A, B, C, D
 IS, Cl. I, Zone 0, AEx ia IIC
 FM Installation Drawing No. 6335QF01

CSA, applicable in..... IS, Cl. I, Div. 1, Gr. A, B, C, D
 Ex ia IIC
 IS, Cl. I, Zone 0, AEx ia IIC
 CSA Installation Drawing No. 6335QC02

GOST R approval:

VNIIFTRI, Cert. no. www.preelectronics.com

Observed authority requirements: Standard:

EMC 2004/108/EC..... EN 61326-1
 ATEX 94/9/EC..... EN 60079-0, -11, -26
 FM..... 3600, 3610, 3611
 CSA, CAN / CSA..... C22.2 No. 157,
 E60079-11, UL 913

Of span = Of the presently selected range