

PERFORMANCE
MADE
SMARTER

Product manual

2240

Transformer

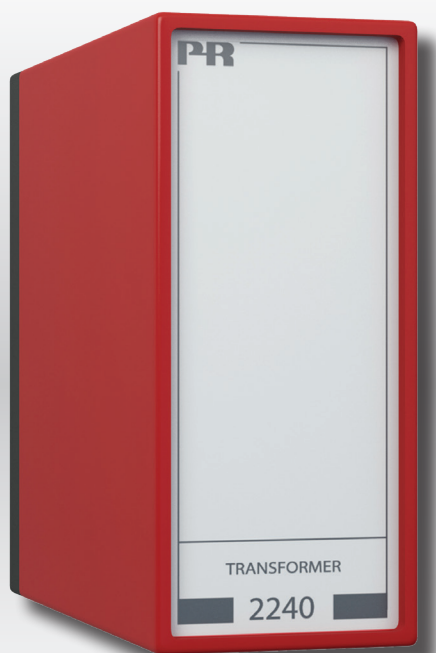

ERC

CE

TEMPERATURE | I.S. INTERFACES | COMMUNICATION INTERFACES | MULTIFUNCTIONAL | ISOLATION | DISPLAY

No. 2240V102-UK
From serial no.: 970279001

PR
electronics

6 Product Pillars

to meet your every need

Individually outstanding, unrivalled in combination

With our innovative, patented technologies, we make signal conditioning smarter and simpler. Our portfolio is composed of six product areas, where we offer a wide range of analog and digital devices covering over a thousand applications in industrial and factory automation. All our products comply with or surpass the highest industry standards, ensuring reliability in even the harshest of environments and have a 5-year warranty for greater peace of mind.



Temperature

Our range of temperature transmitters and sensors provides the highest level of signal integrity from the measurement point to your control system. You can convert industrial process temperature signals to analog, bus or digital communications using a highly reliable point-to-point solution with a fast response time, automatic self-calibration, sensor error detection, low drift, and top EMC performance in any environment.



I.S. Interface

We deliver the safest signals by validating our products against the toughest safety standards. Through our commitment to innovation, we have made pioneering achievements in developing I.S. interfaces with SIL 2 Full Assessment that are both efficient and cost-effective. Our comprehensive range of analog and digital intrinsically safe isolation barriers offers multifunctional inputs and outputs, making PR an easy-to-implement site standard. Our backplanes further simplify large installations and provide seamless integration to standard DCS systems.



Communication

We provide inexpensive, easy-to-use, future-ready communication interfaces that can access your PR installed base of products. All the interfaces are detachable, have a built-in display for readout of process values and diagnostics, and can be configured via push-buttons. Product specific functionality includes communication via Modbus and Bluetooth and remote access using our PR Process Supervisor (PPS) application, available for iOS and Android.



Multifunction

Our unique range of single devices covering multiple applications is easily deployable as your site standard. Having one variant that applies to a broad range of applications can reduce your installation time and training, and greatly simplify spare parts management at your facilities. Our devices are designed for long-term signal accuracy, low power consumption, immunity to electrical noise and simple programming.



Isolation

Our compact, fast, high-quality 6 mm isolators are based on microprocessor technology to provide exceptional performance and EMC-immunity for dedicated applications at a very low total cost of ownership. They can be stacked both vertically and horizontally with no air gap separation between units required.



Display

Our display range is characterized by its flexibility and stability. The devices meet nearly every demand for display readout of process signals, and have universal input and power supply capabilities. They provide a real-time measurement of your process value no matter the industry, and are engineered to provide a user-friendly and reliable relay of information, even in demanding environments.

Transformer

2240

Table of contents

Warning	4
Symbol identification	4
Safety instructions	5
How to dismantle system 9000	6
Application	7
Technical characteristics	7
Mounting	7
Input	7
Output	7
Order	8
Technical data	8
Block diagram	9
Load diagram for max. power output	9
Document history	10

Warning



GENERAL

This device is designed for connection to hazardous electric voltages. Ignoring this warning can result in severe personal injury or mechanical damage. To avoid the risk of electric shock and fire, the safety instructions of this manual must be observed and the guidelines followed. The specifications must not be exceeded, and the device must only be applied as described in the following. Prior to the commissioning of the device, this manual must be examined carefully. Only qualified personnel (technicians) should install this device. If the equipment is used in a manner not specified by the manufacturer, the protection provided by the equipment may be impaired.

Warning



**HAZARD-
OUS
VOLTAGE**

Until the device is fixed, do not connect hazardous voltages to the device. The following operations should only be carried out on a disconnected device and under ESD-safe conditions:

- Dismantlement of the device for setting of DIP-switches and jumpers.
- General mounting, wire connection and disconnection.
- Troubleshooting the device.

Repair of the device and replacement of circuit breakers must be done by PR electronics A/S only.



Warning



**INSTAL-
LATION**

To keep the safety distances, devices with two built-in relays must not be connected to both hazardous and non-hazardous voltages on the same device's relay contacts.

SYSTEM 2200 must be mounted in socket type S3B Releco (order no 7023).

Symbol identification



Triangle with an exclamation mark: Read the manual before installation and commissioning of the device in order to avoid incidents that could lead to personal injury or mechanical damage. Warning/demand. Potentially lethal situations.



The CE mark proves the compliance of the device with the essential requirements of the directives.



The double insulation symbol shows that the device is protected by double or reinforced insulation.

Safety instructions

Definitions

Hazardous voltages have been defined as the ranges: 75 to 1500 Volt DC, and 50 to 1000 Volt AC.

Technicians are qualified persons educated or trained to mount, operate, and also trouble-shoot technically correct and in accordance with safety regulations.

Operators, being familiar with the contents of this manual, adjust and operate the knobs or potentiometers during normal operation.

Receipt and unpacking

Unpack the device without damaging it and check whether the device type corresponds to the one ordered. The packing should always follow the device until this has been permanently mounted.

Environment

Avoid direct sun light, dust, high temperatures, mechanical vibrations and shock, and rain and heavy moisture. If necessary, heating in excess of the stated limits for ambient temperatures should be avoided by way of ventilation.

All devices fall under Installation Category II, Pollution Degree 2, and Insulation Class II.

Mounting

Only technicians, who are familiar with the technical terms, warnings, and instructions in the manual and who are able to follow these, should connect the device. Should there be any doubt as to the correct handling of the device, please contact your local distributor or, alternatively,

PR electronics A/S
www.prelectronics.com

Mounting and connection of the device should comply with national legislation for mounting of electric materials, i.a. wire cross section, protective fuse, and location.

Descriptions of Input / Output and supply connections are shown in the block diagram and side label.

The following apply to fixed hazardous voltages-connected devices:

The max. size of the protective fuse is 10 A and, together with a power switch, it should be easily accessible and close to the device. The power switch should be marked with a label telling it will switch off the voltage to the device.

Year of manufacture can be taken from the first two digits in the serial number.

Calibration and Adjustment

During calibration and adjustment, the measuring and connection of external voltages must be carried out according to the specifications of this manual. The technician must use tools and instruments that are safe to use.

Normal operation

Operators are only allowed to adjust and operate devices that are safely fixed in panels, etc., thus avoiding the danger of personal injury and damage. This means there is no electrical shock hazard, and the device is easily accessible.

Cleaning

When disconnected, the device may be cleaned with a cloth moistened with distilled water.

Liability

To the extent the instructions in this manual are not strictly observed, the customer cannot advance a demand against PR electronics A/S that would otherwise exist according to the concluded sales agreement.

How to dismantle system 9000

The back panel of the device is detached from the housing by way of a screw-driver as shown in picture 1.

On a device with knobs, these must be removed before the PCB can be taken out as shown in picture 2.

After this, the back panel can be pulled out together with the PCB, but please notice the position of the PCB as there is a number of different positions in the house. Do not pull the wires unnecessarily, instead pull the PCB, see picture 3.

Switches and jumpers can now be moved.

When assembling the back plate and housing, please make sure no wires are stuck.

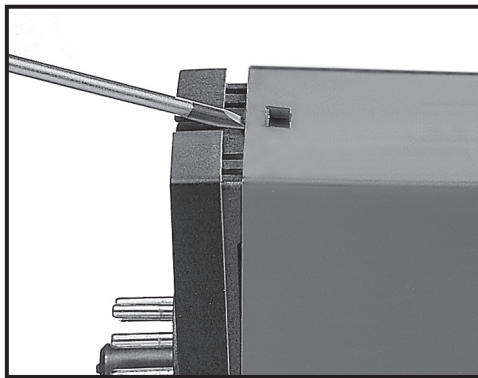

Picture 1: Dismantlement of back plate and housing.



Picture 2: Removal of knobs.

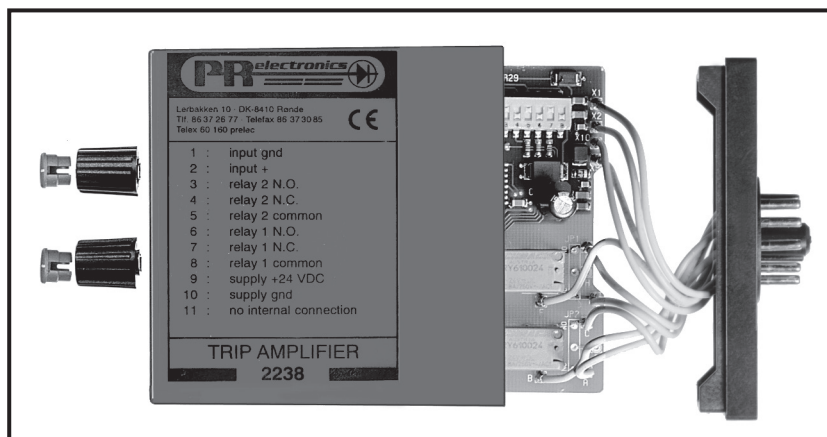

Picture 3: Removal of PCBs for adjustment of DIP-switches and replacement of jumpers.

Transformer

2240

- Double-isolated transformer
- 3.75 kVAC isolation voltage
- 30 VA ring core transformer
- Thermal overload protection
- 12 or 24 VAC secondary voltage
- Standard 11-pole relay socket

Application

- Transformer for supply of components with 12 or 24 VAC supply voltage.
- Transformer for stabilized DC power supplies, e.g. type 2229.
- Suitable for PELV/SELV applications.

Technical characteristics

- Ring core transformer with separate 3.75 kVAC isolation voltage between primary and secondary windings.
- The transformer is fitted with a thermal 100°C fuse.
- Two transformers may be paralleled for higher output power.
- The transformer is molded into the cassette and should be mounted with 10 mm distance to the adjacent cassette for optimal cooling.
- The load diagram shows the relation between the ambient temperature and maximum VA output.

Mounting

- The 2240 is for standard 11-pole socket mounting in all positions. To achieve maximum cooling of the device, mounting in a vertical position at a distance of 10 mm between neighbouring units is recommended.
- The device is supplied with a retention clip for a safe attachment to the relay socket.

Input

- Standard primary voltages of 115 or 230 VAC.

Output

- Standard secondary voltages of 12 or 24 VAC. Max DC power after rectification and stabilization: 20 W.

Order

Type	Input	Output
2240	115 VAC : A	24 VAC : 1
	230 VAC : B	12 VAC : 5

Technical data

Environmental conditions:

Specifications range	-20°C to +60°C
Storage temperature	-20°C to +85°C
Relative humidity	< 95% RH (non-cond.)
Protection degree	IP50

Mechanical specifications:

Dimensions (HxWxD)	80.5 x 35.5 x 84.5 mm
Weight approx.	600 g

Common electrical specifications:

Isolation, test / operation.	3.75 kVAC / 250 VAC
Power derating.	Tamb. > 25°C, 0.4 VA/°C
EMC immunity influence	< ±0.5% of span

Input:

Primary voltage	207...253 VAC
	97.75...132.25 VAC
Frequency.	50...60 Hz

Output:

Secondary voltage (loaded)	24 VAC / 1.25 A
Secondary voltage (unloaded).	28 VAC
Secondary voltage (loaded)	12 VAC / 2.50 A
Secondary voltage (unloaded).	14 VAC

Observed authority requirements:

EMC.	2014/30/EU
LVD.	2014/35/EU
RoHS.	2011/65/EU
EAC.	TR-CU 020/2011

Of span = Of the presently selected range

Block diagram

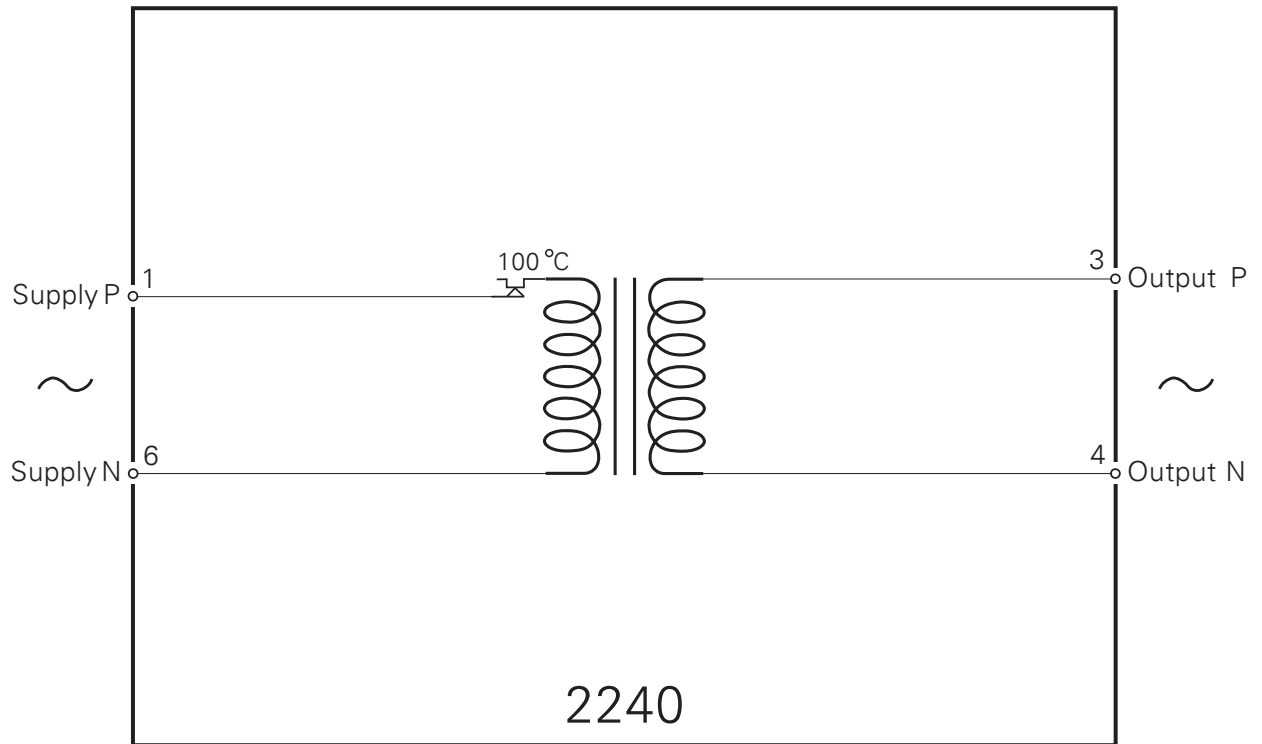

Load diagram for max. power output

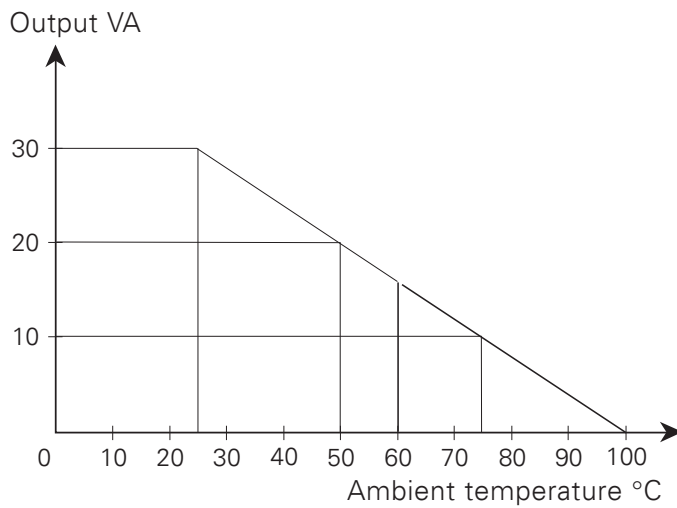

Document history

The following list provides notes concerning revisions of this document.

Rev. ID	Date	Notes
102	1947	Production of version 2240X0 discontinued.

We are near you, *all over the world*

Our trusted red boxes are supported wherever you are

All our devices are backed by expert service and a 5-year warranty. With each product you purchase, you receive personal technical support and guidance, day-to-day delivery, repair without charge within the warranty period and easily accessible documentation.

We are headquartered in Denmark, and have offices and authorized partners the world over. We are a local

business with a global reach. This means that we are always nearby and know your local markets well. We are committed to your satisfaction and provide PERFORMANCE MADE SMARTER all around the world.

For more information on our warranty program, or to meet with a sales representative in your region, visit prelectronics.com.

Benefit today from *PERFORMANCE MADE SMARTER*

PR electronics is the leading technology company specialized in making industrial process control safer, more reliable and more efficient. Since 1974, we have been dedicated to perfecting our core competence of innovating high precision technology with low power consumption. This dedication continues to set new standards for products communicating, monitoring and connecting our customers' process measurement points to their process control systems.

Our innovative, patented technologies are derived from our extensive R&D facilities and from having a great understanding of our customers' needs and processes. We are guided by principles of simplicity, focus, courage and excellence, enabling some of the world's greatest companies to achieve PERFORMANCE MADE SMARTER.