

PERFORMANCE
MADE
SMARTER

Safety manual

9203

Solenoid / alarm driver



TEMPERATURE | I.S. INTERFACES | COMMUNICATION INTERFACES | MULTIFUNCTIONAL | ISOLATION | DISPLAY

Version No. V7R0

PR
electronics

6 Product Pillars

to meet your every need

Individually outstanding, unrivalled in combination

With our innovative, patented technologies, we make signal conditioning smarter and simpler. Our portfolio is composed of six product areas, where we offer a wide range of analog and digital devices covering over a thousand applications in industrial and factory automation. All our products comply with or surpass the highest industry standards, ensuring reliability in even the harshest of environments and have a 5-year warranty for greater peace of mind.



Temperature

Our range of temperature transmitters and sensors provides the highest level of signal integrity from the measurement point to your control system. You can convert industrial process temperature signals to analog, bus or digital communications using a highly reliable point-to-point solution with a fast response time, automatic self-calibration, sensor error detection, low drift, and top EMC performance in any environment.



I.S. Interface

We deliver the safest signals by validating our products against the toughest safety standards. Through our commitment to innovation, we have made pioneering achievements in developing I.S. interfaces with SIL 2 Full Assessment that are both efficient and cost-effective. Our comprehensive range of analog and digital intrinsically safe isolation barriers offers multifunctional inputs and outputs, making PR an easy-to-implement site standard. Our backplanes further simplify large installations and provide seamless integration to standard DCS systems.



Communication

We provide inexpensive, easy-to-use, future-ready communication interfaces that can access your PR installed base of products. All the interfaces are detachable, have a built-in display for readout of process values and diagnostics, and can be configured via push-buttons. Product specific functionality includes communication via Modbus and Bluetooth and remote access using our PR Process Supervisor (PPS) application, available for iOS, Android and Windows.



Multifunction

Our unique range of single devices covering multiple applications is easily deployable as your site standard. Having one variant that applies to a broad range of applications can reduce your installation time and training, and greatly simplify spare parts management at your facilities. Our devices are designed for long-term signal accuracy, low power consumption, immunity to electrical noise and simple programming.



Isolation

Our compact, fast, high-quality 6 mm isolators are based on microprocessor technology to provide exceptional performance and EMC-immunity for dedicated applications at a very low total cost of ownership. They can be stacked both vertically and horizontally with no air gap separation between units required.



Display

Our display range is characterized by its flexibility and stability. The devices meet nearly every demand for display readout of process signals, and have universal input and power supply capabilities. They provide a real-time measurement of your process value no matter the industry, and are engineered to provide a user-friendly and reliable relay of information, even in demanding environments.

SAFETY MANUAL

SOLENOID / ALARM DRIVER

9203

This safety manual is valid for the following product versions:

9203-001
9203-002
9203-003

1. Observed standards	4
2. Acronyms and abbreviations.....	4
3. Purpose of the product.....	4
4. Assumptions and restrictions for use of the product	4
4.1 Basic safety specifications.....	4
4.2 Associated equipment	5
4.2.1 Safety output	5
4.2.2 Safety input.....	5
4.3 Failure rates	5
4.4 Safe parameterization.....	5
4.5 Installation in hazardous areas	5
5. Functional specification of the safety functions.....	5
6. Functional specification of the non-safety functions.....	5
7. Safety parameters.....	5
8. Hardware and software configuration.....	6
9. Failure category	6
10. Periodic proof test procedure.....	6
11. Procedures to repair or replace the product	6
12. Maintenance.....	6
13. Documentation for routing diagram	7
13.1 In general	7
13.2 Further explanations.....	7
13.2.1 Password protection.....	7
13.3 Advanced functions	7
13.3.1 Display setup	7
13.3.2 Password	7
13.3.3 Language.....	7
13.3.4 Power rail	7
13.3.5 Safety integrity level.....	7
14. Safe parameterization - user responsibility	8
14.1 Safety-related configuration parameters	8
14.2 Verification procedure.....	8
14.2.1 If no password is set	8
14.2.2 If password is set.....	9
14.3 Functional test.....	9
15. Fault reaction and restart condition.....	9
16. User interface	10
16.1 Scrolling help texts in display line 3	10
16.2 Routing diagram.....	11
16.3 Routing diagram, advanced settings (ADV.SET).....	12
17. Connections.....	13

1. Observed standards

Standard	Description
IEC 61508	Functional Safety of electrical / electronic / programmable electronic safety-related systems
IEC 61508-2:2000	Part 2: Requirements for electrical / electronic / programmable electronic safety-related systems
IEC 61508-3:1998	Part 3: Software requirements
IEC 61326-3-1:2008	Immunity requirements for safety-related systems

2. Acronyms and abbreviations

Acronym / Abbreviation	Designation	Description
Element		Term defined by IEC 61508 as “part of a subsystem comprising a single component or any group of components that performs one or more element safety functions”
PFD	Probability of Failure on Demand	This is the likelihood of dangerous safety function failures occurring on demand.
PFH	Probability of dangerous Failure per Hour	The term “Probability” is misleading, as IEC 61508 defines a Rate.
SFF	Safe Failure Fraction	Safe Failure Fraction summarizes the fraction of failures which lead to a safe state and the fraction of failures which will be detected by diagnostic measures and lead to a defined safety action.
SIF	Safety Integrity Function	Function that provides fault detection (to ensure the necessary safety integrity for the safety functions)
SIL	Safety Integrity Level	The international standard IEC 61508 specifies four discrete safety integrity levels (SIL 1 to SIL 4). Each level corresponds to a specific probability range regarding the failure of a safety function.

3. Purpose of the product

The 9203Bxxx can be mounted in the safe area or in zone 2 / div. 2 and transmit signals to zone 0, 1, 2 and zone 20, 21, 22 including M1 mining / Class I/II/III, Div. 1, Gr. A-G. Ex driver for the control of ON / OFF solenoids, acoustic alarms and LEDs mounted in the hazardous area.

The 9203Axxx can be mounted in the safe area or zone 2 / div. 2 and transmit signals to non-hazardous area. Driver for the control of ON / OFF solenoids, acoustic alarms and LEDs mounted in safe area.

The 9203 is controlled by an NPN/PNP signal or a switch signal.

Monitoring of internal error events via the individual status relay and/or a collective electronic signal via the power rail.

The 9203 has been designed, developed and certified for use in SIL 2 applications according to the requirements of IEC 61508.

4. Assumptions and restrictions for use of the product

4.1 Basic safety specifications

Operational temperature range	-20...+60°C
Storage temperature range.	-20...+85°C
Power supply type, min.	Double or reinforced
Supply voltage	19.2...31.2 VDC
Mounting area	Zone 2 / Division 2 or safe area
Mounting environment	Pollution degree 2 or better

4.2 Associated equipment

4.2.1 Safety output

The safety output shall be connected to the equipment with a minimum load of 10 K Ω

4.2.2 Safety input

The safety input signal frequency shall not be higher than 20 Hz, and the pulse length shall not be shorter than 25 ms.

4.3 Failure rates

The basic failure rates from the Siemens standard SN 29500 are used as the failure rate database.

Failure rates are constant, wear-out mechanisms are not included.

External power supply failure rates are not included.

4.4 Safe parameterization

The user is responsible for verifying the correctness of the configuration parameters. (See section 14 Safe parameterization - user responsibility).

Manual override may not be used for safety applications.

4.5 Installation in hazardous areas

The IECex Installation drawing, ATEX Installation drawing, INMETRO Installation drawing and FM Installation drawing shall be followed if the products are installed in hazardous areas.

5. Functional specification of the safety functions

Driver for the control of ON / OFF solenoids, acoustic alarms and LEDs.

6. Functional specification of the non-safety functions

The status relay (terminal 33 and 34), error signal on power rail (terminal 91) and LED outputs are not suitable for use in any Safety Instrumented Function.

7. Safety parameters

	9203x1xx	9203x2xx
Probability of dangerous Failure per Hour (PFH)	4.30E-08	4.60E-08
	Note ¹	
Probability of failure on demand (PFD) - 1 year proof test interval	2.73E-04	2.92E-04
Proof test interval (10% of loop PFD)	5 years	4 years
Safe Failure Fraction	91%	91%
Demand response time	<10 ms	
Demand mode	High	
Demand rate	1000 s	
Mean Time To Repair (MTTR)	24 hours	
Diagnostic test interval	10 seconds	
Hardware Fault Tolerance (HFT)	0	
Component Type	B	
SIL capability	SIL 2	
Description of the "Safe State"	De-energized	

Note¹: The 9203 contains no lifetime limiting components, therefore the PFH figures are valid for up to 12 years, according to IEC 61508.

8. Hardware and software configuration

All configurations of software and hardware versions are fixed from factory, and cannot be changed by end-user or reseller. This manual only covers products labelled with the product version (or range of versions) specified on the front page.

9. Failure category

Failure category	Failure rates (1/h)	
	9203x1xx	9203x2xx
Fail Safe Detected	0.00E+00	0.00E+00
Fail Safe Undetected	4.77E-07	4.80E-07
Fail Dangerous Detected	0.00E+00	0.00E+00
Fail Dangerous Undetected	4.30E-08	4.60E-08

10. Periodic proof test procedure

Step	Action
1	Bypass the safety PLC or take other appropriate action to avoid a false trip
2	Connect a simulator identical to the input setup
3	Perform an ON / OFF signal for each channel
4	Observe whether the output channel acts as expected
5	Restore the input terminals to full operation
6	Remove the bypass from the safety PLC or otherwise restore normal operation

This test will detect approximately 95% of possible "du" (dangerous undetected) failures in the device. The proof test is equivalent to the functional test.

11. Procedures to repair or replace the product

Any failures that are detected and that compromise functional safety should be reported to the sales department at PR electronics A/S.

Repair of the device and replacement of circuit breakers must be done by PR electronics A/S only.

12. Maintenance

No maintenance required.

13. Documentation for routing diagram

The routing diagram is shown in section 16.2.

13.1 In general

When configuring the 9203, you will be guided through all parameters and you can choose the settings which fit the application. For each menu there is a scrolling help text which is automatically shown in line 3 on the display. Configuration is carried out by use of the 3 function keys:

- ⬆ will increase the numerical value or choose the next parameter
- ⬇ will decrease the numerical value or choose the previous parameter
- ⊗ will accept the chosen value and proceed to the next menu

When configuration is completed, the display will return to the default state 1.0.

Pressing and holding ⊗ will return to the previous menu or return to the default state (1.0) without saving the changed values or parameters.

If no key is activated for 1 minute, the display will return to the default state (1.0) without saving the changed values or parameters.

13.2 Further explanations

13.2.1 Password protection

Programming access can be blocked by assigning a password. The password is saved in the device in order to ensure a high degree of protection against unauthorized modifications to the configuration. If the configured password is not known, please contact PR electronics support - www.prelectronics.com/contact. Password protection is mandatory in SIL applications.

13.3 Advanced functions

The unit gives access to a number of advanced functions which can be reached by answering "Yes" to the point "adv. set".

13.3.1 Display setup

Here you can adjust the brightness contrast and the backlight. Setup of tag numbers with 5 alphanumeric. Selection of functional readout in line 2 and 3 of the display - choose between readout of digital output or tag no. When selecting "ALT" the readout toggles between digital output and tag no.

13.3.2 Password

Here you can choose a password between 0000 and 9999 in order to protect the device against unauthorized modifications to the configuration. The device is delivered default without password.

13.3.3 Language

In the menu "LANG" you can choose between 7 different language versions of help texts that will appear in the menu. You can choose between UK, DE, FR, IT, ES, SE and DK.

13.3.4 Power rail

In the menu "RAIL" you can choose if errors in the device are transmitted to the central surveillance in the PR 9410 power control unit.

13.3.5 Safety integrity level

See Safe parameterization - user responsibility

14. Safe parameterization - user responsibility

14.1 Safety-related configuration parameters

Parameters	Value	Description
CH1.FUN	DIR / INV	Direct / inverted channel function
CH2.FUN.	DIR / INV	Direct / inverted channel function
PASSW	0 - 9999	New password

The above safety-related configuration parameters are marked in red text in the routing diagrams and must be verified by the user in a SIL-configuration.

14.2 Verification procedure

The verification is done using the display / programming front PR 45xx by following the procedure described below.

14.2.1 If no password is set

	Action	Display shows
1	Press OK	ADV.SET
2	Set (ADV.SET) to Yes and press OK	DISP SETUP
3	Step down to (SIL SETUP) and press OK	EN.SIL
4	Set (EN SIL) to YES and press OK	NEW.PASS
5	Set password to a number between 0 and 9999 and press OK (At this time the device starts operating in SIL mode with the entered configuration parameters!)	Verify⇒OPEN "briefly" ⇒LOCK*
6	Press OK to confirm verification of the OPEN-LOCK in the display	CH1.FUN
7	Verify Channel 1 function and press OK	CH2:FUN
8	Verify Channel 2 function and press OK	PASSW
9	Verify password and press OK	SIL.OK
10	Verify SIL and press OK	

* Open is shown briefly in the display.

14.2.2 If password is set

	Action	Display shows
1	Press OK	PASSW
2	Enter password and press OK	ADV.SET
3	Set (ADV.SET) to Yes and press OK	DISP SETUP
4	Step down to (SIL SETUP) and press OK	EN.SIL
5	Set (EN SIL) to YES and press OK (At this time the device starts operating in SIL mode with the entered configuration parameters!)	Verify⇒OPEN "briefly" ⇒LOCK*
6	Press OK to confirm verification of the OPEN-LOCK in the display	CH1.FUN
7	Verify Channel 1 function and press OK	CH2:FUN
8	Verify Channel 2 function and press OK	PASSW
9	Verify password and press OK	SIL.OK
10	Verify SIL and press OK	

* Open is shown briefly in the display

14.3 Functional test

The user is responsible for making a functional test after verification of safety parameters. The procedure for periodic proof test described in section 10 shall be used.

15. Fault reaction and restart condition

When the 9203 detects a fault the output will go to Safe State, in which the safety output will go to "de-energized". For device faults there are 2 ways of bringing the device out of Safe State.

1. Power cycle the device.
2. Bring the device out of SIL mode (choose "NO" in the menu point "EN.SIL"), and set it back to SIL mode again (choose "YES" in the menu point "EN.SIL" and verify the configuration).

16. User interface

16.1 Scrolling help texts in display line 3

- [01] Set correct password
- [02] Enter advanced setup?
- [06] Enter language setup
 - Enter password setup
 - Enter display setup
 - Enter SIL setup
- [07] Select direct channel function
 - Select inverted channel function
- [09] Adjust LCD contrast
- [10] Adjust LCD backlight
- [11] Write a 5-character channel tag
- [12] Show output state in display
 - Show output load in display
 - Show tag in display
 - Alternate information shown in display
- [13] Configuration SIL status (Open / Locked)
- [14] Enable SIL configuration lock
- [15] Enable password protection?
- [16] Set new password
- [17] Select language
- [20] No communication - check connections
- [21] EEPROM error - check configuration
- [22] Hardware error

16.2 Routing diagram

If no key is activated for 1 minute, the display will return to the default state 1.0 without saving configuration changes.

- ⬆ Increase value / choose next parameter
- ⬇ Decrease value / choose previous parameter
- Ⓚ Save the chosen value and proceed to the next menu
- Hold Ⓚ Back to previous menu / return to menu 1.0 without saving.

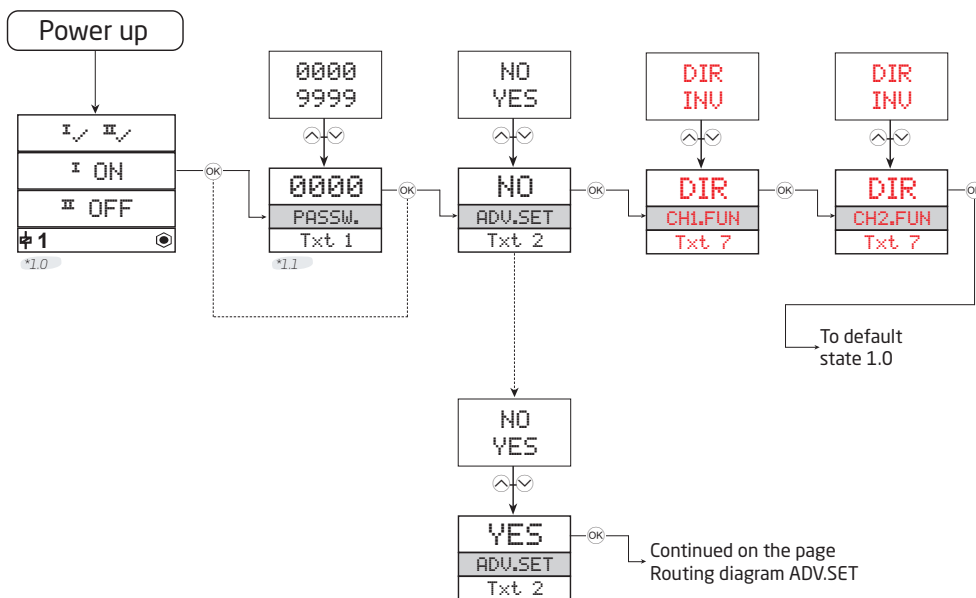

*1.0 Default state.
 Line 1 shows status for channel 1 and channel 2.
 Line 2 shows output status for channel 1, output current or tag no.
 Line 3 shows output status for channel 2, output current or tag no.
 Line 4 indicates whether the device is SIL-locked.

*1.1 Only if password-protected.

Line 1 symbols:
 ⚡✓ = OK. Flashing ⚡! = error.
 Line 2 and 3 symbols:
 ⚡ ON = channel 1 ON
 ⚡ OFF = channel 2 OFF
 Line 4 symbols:
 Static dot = SIL-locked
 Flashing dot = Not SIL-locked
 ⚡ = output is active

Red text signifies safety parameters in a SIL configuration.

16.3 Routing diagram, advanced settings (ADV.SET)

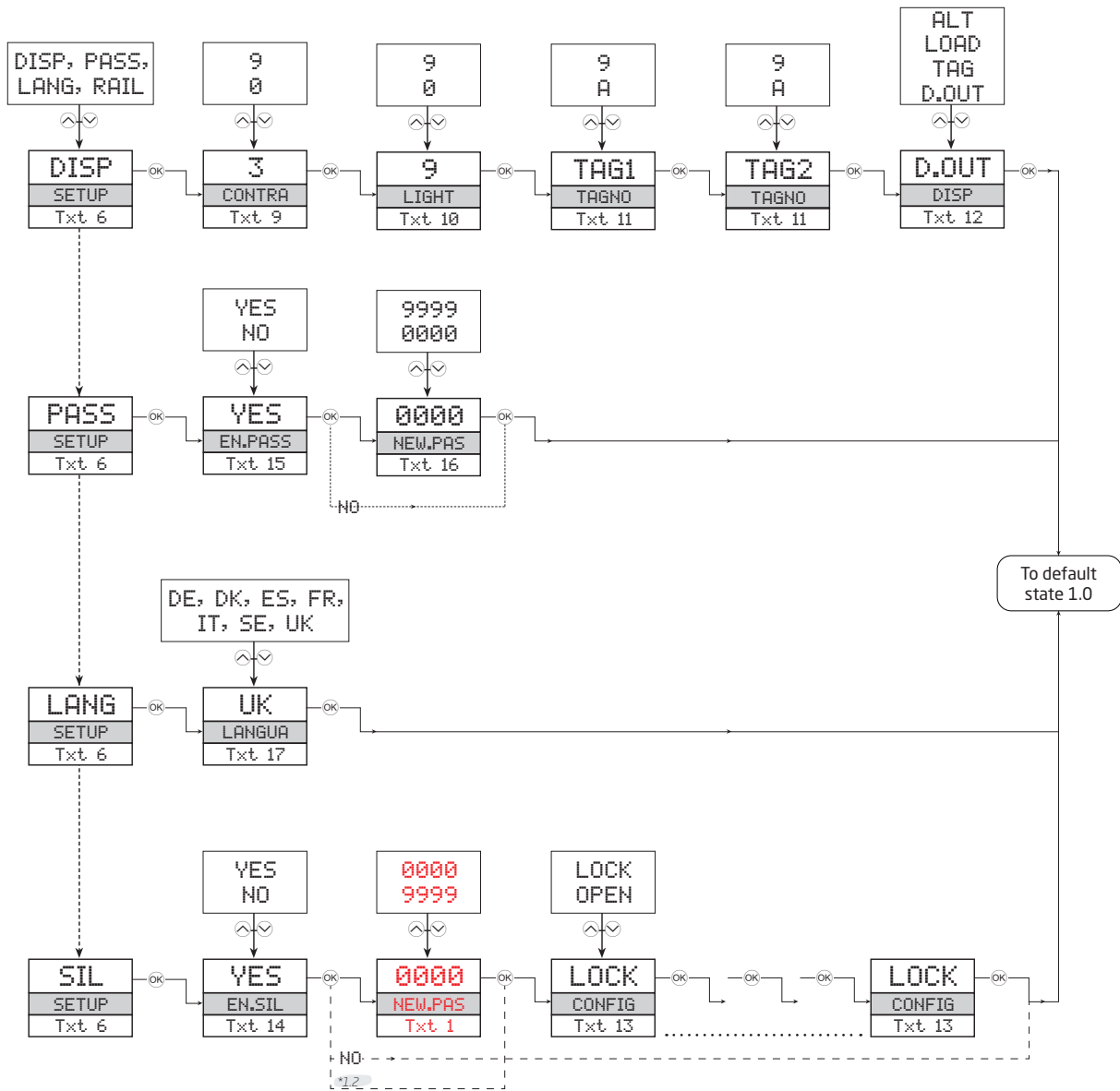

*1.2 If password has been set.

17. Connections

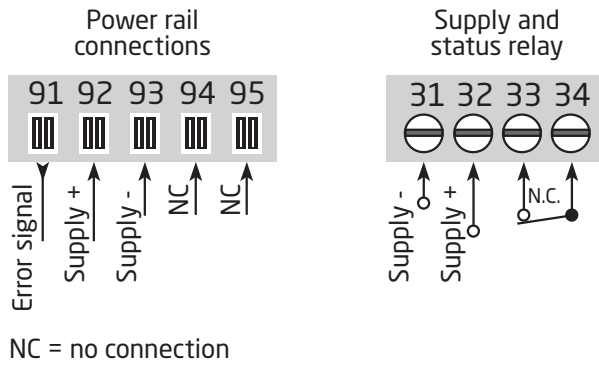

Inputs - 9203xxx-x:

Channel 1

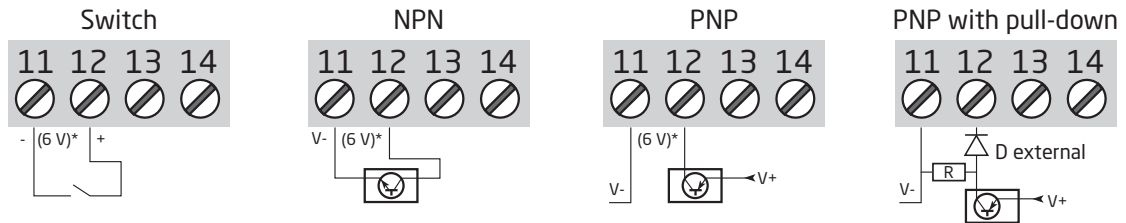

Channel 2

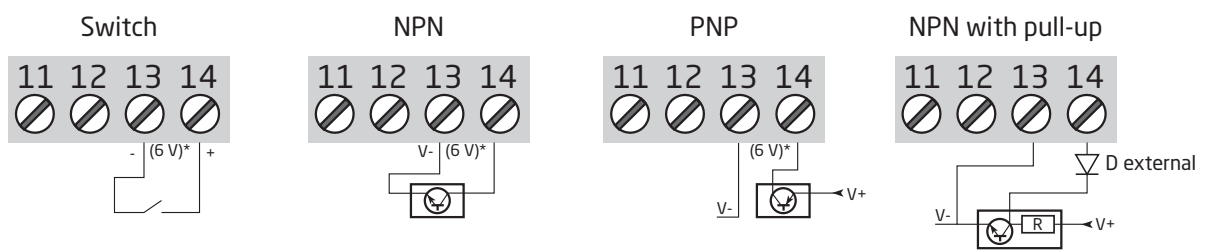

Inputs - 9203xxx1x:

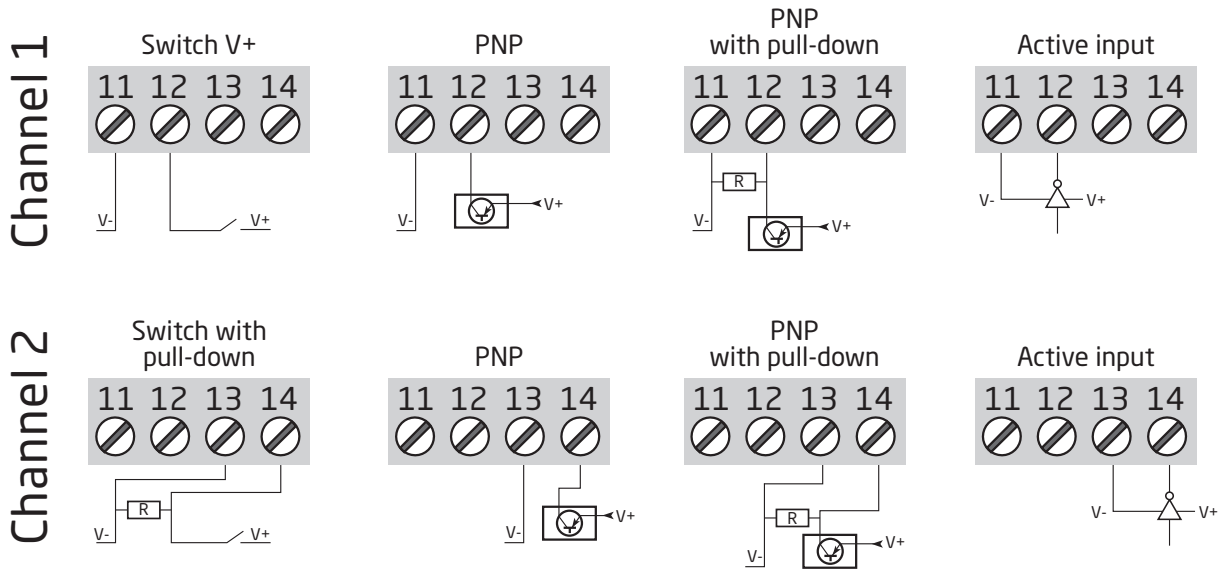

Inputs - 9203xxx2x:

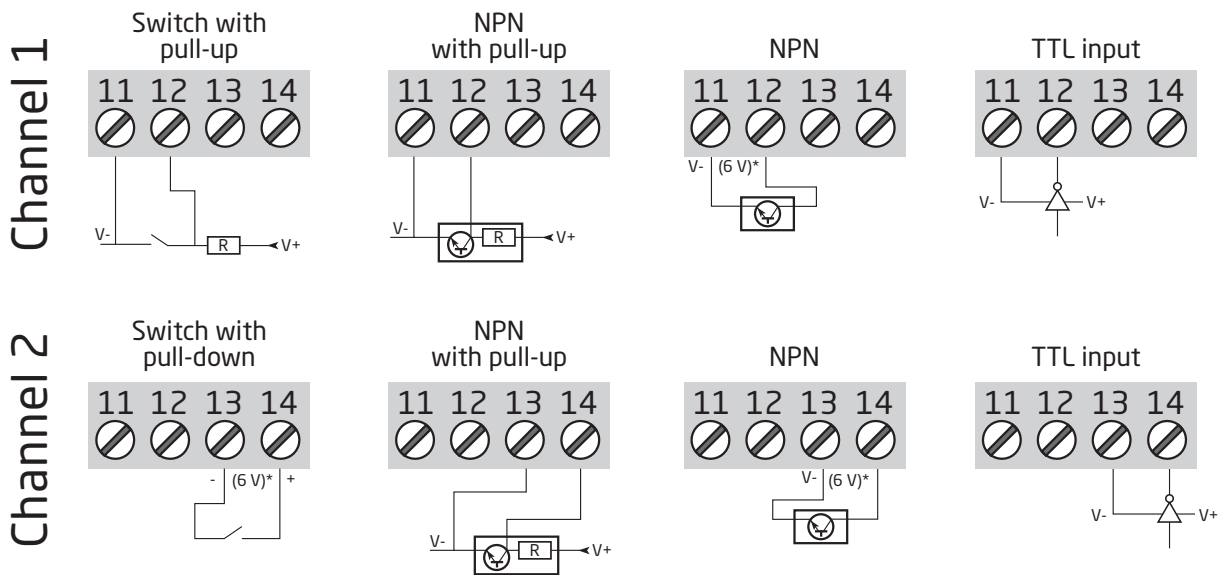

* 6 V at open state

Outputs - 9203xxxxx:

Channel 1

Solenoid, ON / OFF

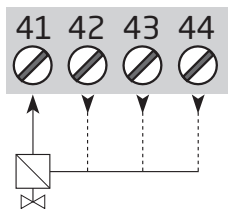

Acoustic alarm

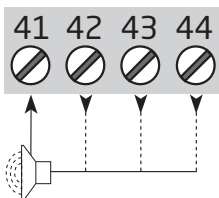

LED

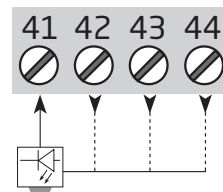

Channel 2

Solenoid, ON / OFF

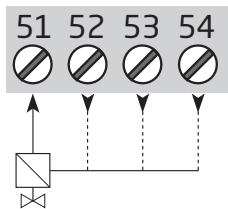

Acoustic alarm

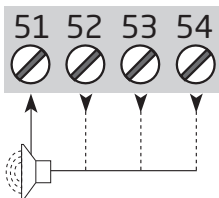

LED

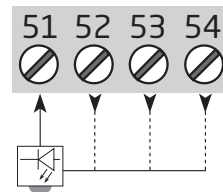

We are near you, *all over the world*

Our trusted red boxes are supported wherever you are

All our devices are backed by expert service and a 5-year warranty. With each product you purchase, you receive personal technical support and guidance, day-to-day delivery, repair without charge within the warranty period and easily accessible documentation.

We are headquartered in Denmark, and have offices and authorized partners the world over. We are a local

business with a global reach. This means that we are always nearby and know your local markets well. We are committed to your satisfaction and provide **PERFORMANCE MADE SMARTER** all around the world.

For more information on our warranty program, or to meet with a sales representative in your region, visit prelectronics.com.

Benefit today from *PERFORMANCE MADE SMARTER*

PR electronics is the leading technology company specialized in making industrial process control safer, more reliable and more efficient. Since 1974, we have been dedicated to perfecting our core competence of innovating high precision technology with low power consumption. This dedication continues to set new standards for products communicating, monitoring and connecting our customers' process measurement points to their process control systems.

Our innovative, patented technologies are derived from our extensive R&D facilities and from having a great understanding of our customers' needs and processes. We are guided by principles of simplicity, focus, courage and excellence, enabling some of the world's greatest companies to achieve PERFORMANCE MADE SMARTER.