

PERFORMANCE
MADE
SMARTER

Product manual **3109**

Isolated converter / splitter

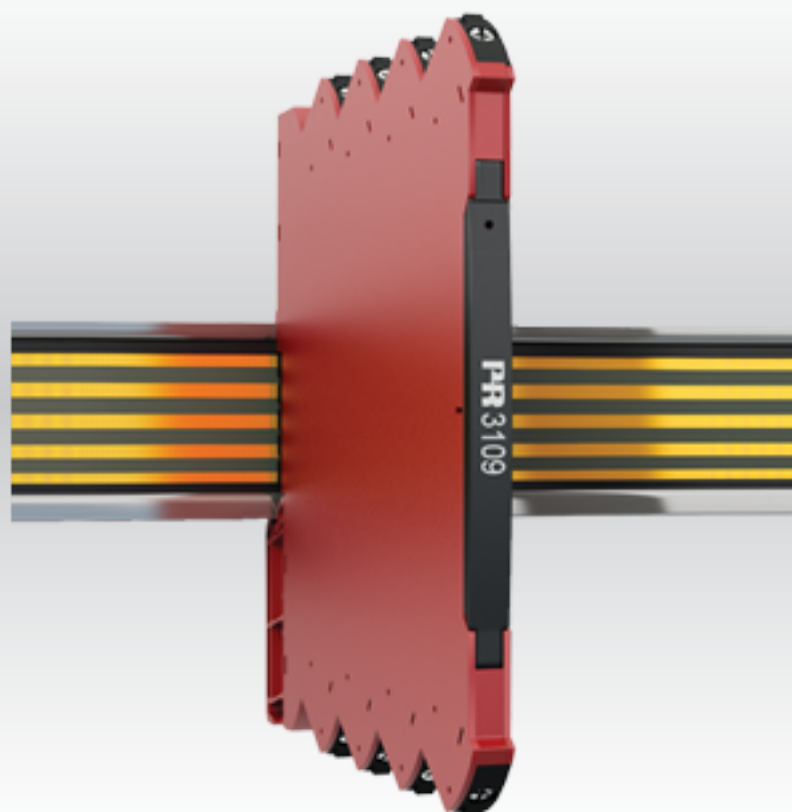

TEMPERATURE | I.S. INTERFACES | COMMUNICATION INTERFACES | MULTIFUNCTIONAL | ISOLATION | DISPLAY

No. 3109V112-EN
From serial no.: 211449001

PR
electronics

6 Product Pillars

to meet your every need

Individually outstanding, unrivalled in combination

With our innovative, patented technologies, we make signal conditioning smarter and simpler. Our portfolio is composed of six product areas, where we offer a wide range of analog and digital devices covering over a thousand applications in industrial and factory automation. All our products comply with or surpass the highest industry standards, ensuring reliability in even the harshest of environments and have a 5-year warranty for greater peace of mind.



Temperature

Our range of temperature transmitters and sensors provides the highest level of signal integrity from the measurement point to your control system. You can convert industrial process temperature signals to analog, bus or digital communications using a highly reliable point-to-point solution with a fast response time, automatic self-calibration, sensor error detection, low drift, and top EMC performance in any environment.



I.S. Interface

We deliver the safest signals by validating our products against the toughest safety standards. Through our commitment to innovation, we have made pioneering achievements in developing I.S. interfaces with SIL 2 Full Assessment that are both efficient and cost-effective. Our comprehensive range of analog and digital intrinsically safe isolation barriers offers multifunctional inputs and outputs, making PR an easy-to-implement site standard. Our backplanes further simplify large installations and provide seamless integration to standard DCS systems.



Communication

We provide inexpensive, easy-to-use, future-ready communication interfaces that can access your PR installed base of products. All the interfaces are detachable, have a built-in display for readout of process values and diagnostics, and can be configured via push-buttons. Product specific functionality includes communication via Modbus and Bluetooth and remote access using our Portable Plant Supervisor (PPS) application, available for iOS, Android.



Multifunction

Our unique range of single devices covering multiple applications is easily deployable as your site standard. Having one variant that applies to a broad range of applications can reduce your installation time and training, and greatly simplify spare parts management at your facilities. Our devices are designed for long-term signal accuracy, low power consumption, immunity to electrical noise and simple programming.



Isolation

Our compact, fast, high-quality 6 mm isolators are based on microprocessor technology to provide exceptional performance and EMC-immunity for dedicated applications at a very low total cost of ownership. They can be stacked both vertically and horizontally with no air gap separation between units required.



Display

Our display range is characterized by its flexibility and stability. The devices meet nearly every demand for display readout of process signals and have universal input and power supply capabilities. They provide a real-time measurement of your process value no matter the industry and are engineered to provide a user-friendly and reliable relay of information, even in demanding environments.

Table of contents

| | |
|---|----|
| Warnings | 4 |
| Symbol identification | 5 |
| Safety instructions | 6 |
| Installation | 7 |
| Mounting / demounting of system 3000 | 7 |
| Installation on DIN rail / power rail | 8 |
| Marking | 8 |
| Flexible supply | 9 |
| Product features | 10 |
| Functional highlights | 10 |
| Technical highlights | 10 |
| Programming | 10 |
| Mounting / installation | 10 |
| Connections | 11 |
| Specifications | 12 |
| Ordering information | 12 |
| Technical specifications | 12 |
| Common electrical specifications | 12 |
| Input and output specifications | 13 |
| Approvals & certificates | 13 |
| Programming | 15 |
| DIP switch configuration | 15 |
| Operation & troubleshooting | 16 |
| Installation instructions | 17 |
| Document history | 18 |

Warnings



WARNING

This device is designed for connection to hazardous electric voltages. Ignoring this warning can result in severe personal injury or mechanical damage.

To avoid the risk of electric shock and fire, the safety instructions in this product manual must be observed and the guidelines followed. The specifications must not be exceeded, and the device must only be applied as described in the following.

Prior to the commissioning of the device, this product manual must be examined carefully.

Only qualified personnel (technicians) should install this device. If the equipment is used in a manner not specified by the manufacturer, the protection provided by the equipment may be impaired.



HAZARDOUS VOLTAGE

Until the device is fixed, do not connect hazardous voltages to the device.

In applications where hazardous voltage is connected to in-/outputs of the device, sufficient spacing or isolation from wires, terminals, and enclosure to surroundings (incl. neighboring devices), must be ensured to maintain protection against electric shock.

Repair of the device and replacement of circuit breakers must be done by PR electronics A/S only.



CAUTION

Potential electrostatic charging hazard. To avoid the risk of explosion due to electrostatic charging of the enclosure, do not handle the units unless the area is known to be safe, or appropriate safety measures are taken to avoid electrostatic discharge.

Symbol identification



Triangle with an exclamation mark: Warning / demand. Potentially lethal situations. Read the manual before installation and commissioning of the device in order to avoid incidents that could lead to personal injury or mechanical damage.



The **CE mark** proves the compliance of the device with the essential requirements of the EU directives.



The **UKCA mark** proves the compliance of the device with the essential requirements of the UK regulations.



The **double insulation symbol** shows that the device is protected by double or reinforced insulation.



Ex devices have been approved acc. to the ATEX directive for use in connection with installations in explosive areas. See installation instructions.

Safety instructions

Definitions

Hazardous voltages have been defined as the ranges: 75 to 1500 Volt DC, and 50 to 1000 Volt AC.

Technicians are qualified persons educated or trained to mount, operate, and troubleshoot the device in accordance with safety regulations.

Operators are personnel familiar with the contents of this manual and capable of safe operation of the device.

Receipt and unpacking

Unpack the device without damaging it and check whether the device type corresponds to the one ordered. The packing should always follow the device until it has been permanently mounted.

Environment

Avoid direct sun light, dust, high temperatures, mechanical vibrations and shock, and rain and heavy moisture. If necessary, heating in excess of the stated limits for ambient temperatures should be avoided by way of ventilation.

The device must be installed in pollution degree 2 or better.

The device is designed to be safe up to an altitude of 2 000 m.

The device is designed for indoor use.

Mounting

Only technicians who are familiar with the technical terms, warnings, and instructions in the manual and who are able to follow these should connect the device. Should there be any doubt as to the correct handling of the device, please contact your local distributor or, alternatively, contact PR electronics A/S at www.prelectronics.com

Mounting and connection of the device should comply with national legislation for mounting of electric materials, e.g. wire cross section, protective fuse, and location.

Descriptions of input / output and supply connections are shown in the block diagram and side label.

The device must be supplied from a Power Supply with electrical protection feature SELV or otherwise confirmed to have double or reinforced insulation. A power switch should be easily accessible and close to the device. The power switch shall be marked as the disconnecting unit for the device.

SYSTEM 3000 must be mounted on a DIN rail according to EN 60715.

Year of manufacture can be taken from the first two digits in the serial number.

Calibration and adjustment

During calibration and adjustment, the measuring and connection of external voltages must be carried out according to the specifications of this manual. The technician must use tools and instruments that are safe to use.

Normal operation

Operators are only allowed to adjust and operate devices that are safely fixed in panels, etc., thus avoiding the danger of personal injury and damage. This means there is no electrical shock hazard, and the device is easily accessible.

Cleaning

When disconnected, the device may be cleaned with a cloth moistened with distilled water.

Liability

To the extent the instructions in this manual are not strictly observed, the customer cannot advance a demand against PR electronics A/S that would otherwise exist according to the concluded sales agreement.

Installation

Mounting / demounting of system 3000

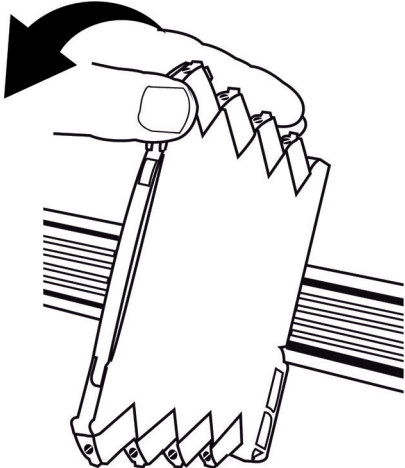
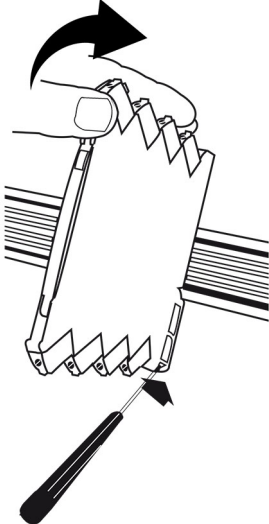
| Mounting on DIN rail (Fig. 1) | Demounting from DIN rail (Fig. 2) |
|--|---|
| Click the device onto the DIN rail. | First, remember to demount the connectors with hazardous voltages. Detach the device from the rail by moving the bottom lock down |
|  |  |



WARNING

System 3000 devices can be mounted on DIN rail or power rail (where applicable). When installing system 3000 devices with power rail connectors on a standard 7.5 mm DIN rail the head of the screws holding the rail shall be no more than 3.5 mm high to prevent potential short circuit of the power rail connectors.

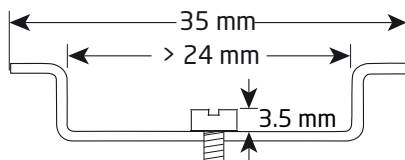

Installation on DIN rail / power rail

The device can be installed on a DIN rail or on a power rail.

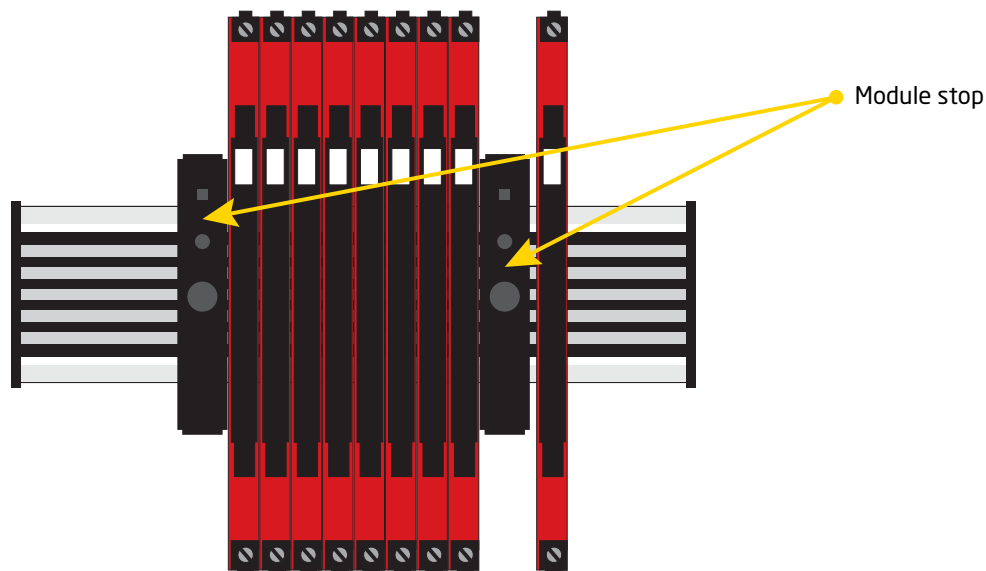

Power supply units can be mounted on the power rail according to customer requirements.



WARNING

For marine applications, the devices must be supported by a module stop (PR part number 9404).

Marking

The front cover of the device has been designed with an area for affixation of a click-on marker. The area assigned to the marker measures 5 x 7.5 mm. Markers from Weidmüller's MultiCard System, type MF 5/7.5, are suitable.

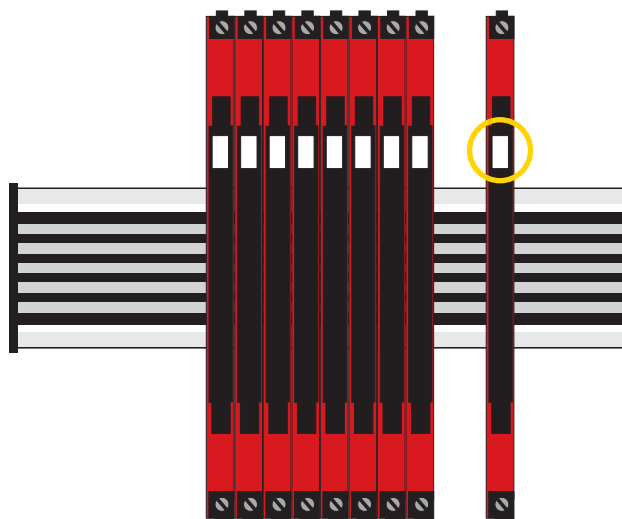

Flexible supply

The technical specifications specify the maximum required power at nominal operating values, e.g. 24 V supply voltage, 60°C ambient temperature, 600 Ω load, and 20 mA output current. External protective fuses may be required depending on power source selected. Protective fuse ratings are specified below.

DIN rail solution - device daisy chain:

The units can be supplied with 24 VDC ±30% via direct wiring and a loop between the devices.

Protective fuse: 2.5 A

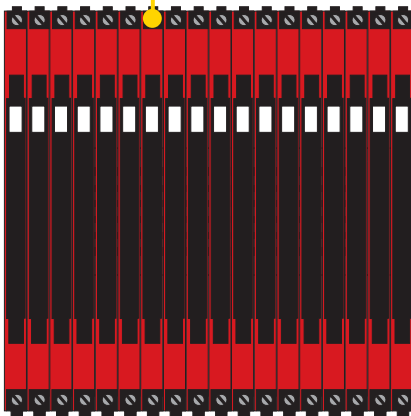

Protective fuse: 0.4 A

Power rail solution #1

Alternately, you can connect 24 VDC to any 3000 device with power rail connector which will then energize other units on the rail.

Power rail solution #2:

The PR 3405 power connector unit allows easy connection of a 24 VDC / 2.5 A source to the power rail.

Protective fuse: 2.5 A

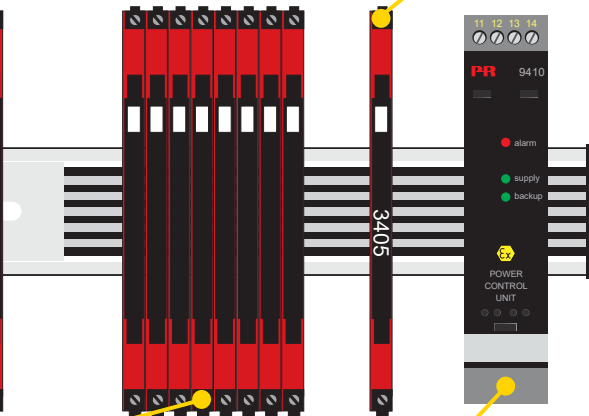

Protective fuse: Located inside the PR 9410

Power rail solution #3:

The PR 9410 power control unit can energize and power 96 W to the rail. Redundant power supplies are possible.

Note

Device types 3xxx-N do not have power rail connectors and can only be supplied with direct wiring on each device.

External fuse characteristics

The 2.5 A fuse must break after not more than 120 seconds at 6.4 A.

Product features

- Isolation and conversion of standard DC signals
- Power supply and signal isolator for 2-wire transmitter
- Splitter function: 1 in - 2 out
- DIP switch configuration
- Slimline 6.1 mm housing

Functional highlights

- Galvanic separation of analog current and voltage signals.
- A competitive choice in terms of both price and technology for galvanic isolation of all signal types to SCADA systems or PLC equipment.
- High 4-port isolation provides surge suppression that protects the control system from transients and noise and eliminates ground loops.
- All terminals are over-voltage protected, polarity protected and short-circuit protected.
- The device can be mounted in Safe area or in Zone 2 / Division 2 areas and is approved for marine applications.

Technical highlights

- Flexible 24 VDC ($\pm 30\%$) supply via power rail or connectors.
- Factory-calibrated measurement ranges.
- Fast response time < 7 ms.
- Excellent signal / noise ratio > 60 dB.
- High galvanic isolation of 2.5 kVAC.
- Inputs and outputs are floating and galvanically separated.
- A green front LED indicates normal operation and malfunction.
- Wide ambient temperature range: $-25\dots+70^{\circ}\text{C}$.

Programming

- Easy configuration via DIP switches.

Mounting / installation

- The narrow 6.1 mm housing allows up to 163 units per meter.
- Units can be mounted side by side, horizontally and vertically, without air gap on a standard DIN rail, even at 70°C ambient temperature.
- Units can be supplied separately or installed on PR 9400 power rail.

Connections

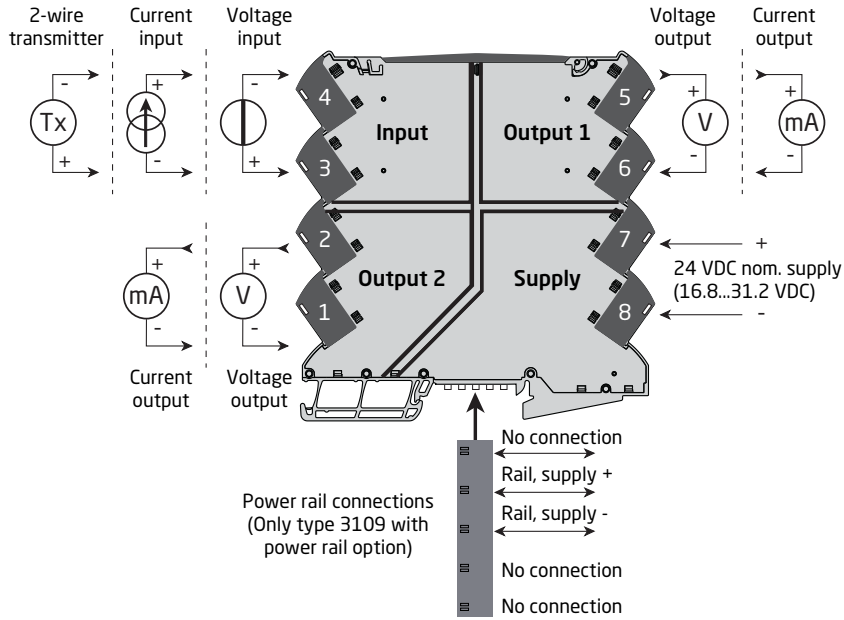

Specifications

Ordering information

Product variants

| Type | Version | | |
|------|-------------------------------|---------------------------------------|------|
| 3109 | Isolated converter / splitter | With power rail connector / terminals | : - |
| | | Supplied via terminals | : -N |

Example: 3109-N (Isolated converter / splitter, supplied via terminals)

Accessories

9404 = Module stop for rail

9421 = Power supply

Accessories for power rail devices

3405 = Power rail connector unit

9400 = Power rail - 7.5 or 15 mm high

9410 = Power control unit

Technical specifications

Environmental conditions

| | |
|-----------------------------------|--|
| Operating temperature | -25...+70°C |
| Storage temperature | -40...+85°C |
| Calibration temperature | 20...28°C |
| Relative humidity | < 95% RH non condensing |
| Protection degree. | IP20 |
| Installation in | Pollution degree 2 & meas. / overvoltage cat. II |

Mechanical specifications

| | |
|-----------------------------------|--|
| Dimensions (HxWxD) | 113 x 6.1 x 115 mm |
| Weight approx. | 70 g |
| DIN rail type | 35 x 15 mm DIN rail (EN 60715) |
| Wire size. | 0.13...2.5 mm ² / AWG 26...12 stranded wire |
| Screw terminal torque | 0.5 Nm |
| Vibration, IEC 60068-2-6. | 2...25 Hz = ±1.6 mm, 25...100 Hz = ±4 g |

Common electrical specifications

| | |
|----------------------------------|-----------------|
| Supply voltage | 16.8...31.2 VDC |
| Max. required power | 1.2 W |
| Max. power dissipation | 0.6 W |

Max. required power is the maximum power needed at power supply terminals or rail connector.

Max. power dissipation is the maximum power dissipated at nominal operating values.

| | |
|--------------------------------------|---|
| Isolation voltage, test | 2.5 kVAC |
| Isolation voltage, working | 300 VAC (reinforced) / 250 VAC (Zone 2, Div. 2) |

Specifications

| | |
|--|--------------------------------------|
| Double isolation | Input / output 1 / output 2 / supply |
| Signal dynamics, input / output | Analog signal chain |
| Signal / noise ratio | > 60 dB |
| Response time (0...90%, 100...10%) | < 7 ms |
| Programming | DIP switches |
| Cut- off frequency (3 dB) | > 100 Hz |

| Accuracy values | | |
|-----------------|---------------------------|--------------------------------|
| Input type | Absolute accuracy | Temperature coefficient |
| All | $\leq \pm 0.05\%$ of span | $\leq \pm 0.01\%$ of span / °C |

| | |
|---|-----------------------|
| EMC immunity influence | < $\pm 0.5\%$ of span |
| Extended EMC immunity: NAMUR NE 21, A criterion, burst | < $\pm 1\%$ of span |
| Auxiliary supplies: 2-wire supply (terminal 3 and 4) | > 17 VDC / 20 mA |

Input and output specifications

Current input

| | |
|---|------------------------------------|
| Measurement range. | 0...23 mA |
| Input voltage drop | < 1.5 VDC |
| Input resistance. | Nom. 20 Ω + PTC 50 Ω |
| Programmable measurement ranges | 0...20 and 4...20 mA |

Voltage input

| | |
|---|-------------------------------------|
| Measurement range. | 0...10.25 VDC |
| Input resistance. | ≥ 500 k Ω |
| Programmable measurement ranges | 0...10 / 2...10 / 0...5 / 1...5 VDC |

Current output

| | |
|--------------------------------------|---------------------------------------|
| Signal range (span) | 0...23 mA |
| Load | ≤ 300 Ω per channel |
| Load stability | $\leq 0.002\%$ of span / 100 Ω |
| Current limit. | ≤ 28 mA |
| Programmable signal ranges | 0...20 and 4...20 mA |

Voltage output

| | |
|--------------------------------------|--------------------------------|
| Signal range. | 0...10 VDC |
| Programmable signal ranges | 0...5, 1...5, 0...10, 2...10 V |
| Load | >10 k Ω |

of span = of the selected range

Approvals & certificates

Observed authority requirements

| | |
|---------------|------------------------------|
| EMC | 2014/30/EU & UK SI 2016/1091 |
| LVD | 2014/35/EU & UK SI 2016/1101 |

| | |
|-----------------|------------------------------|
| RoHS. | 2011/65/EU & UK SI 2012/3032 |
| ATEX. | 2014/34/EU & UK SI 2016/1107 |
| EAC | TR-CU 020/2011 |
| EAC Ex. | TR-CU 012/2011 |

Approvals

| | |
|---------------------------------|------------|
| c UL us, UL 61010-1 | E314307 |
| DNV, Ships & Offshore | TAA00001Rw |

I.S. / Ex approvals

| | |
|-------------------|-----------------------------|
| ATEX. | KEMA 10ATEX0147X |
| IECEX. | KEM 10.0068X |
| UKEX. | DEKRA 21UKEX0055X |
| c FM us | FM17US0004X / FM17CA0003X |
| EAC Ex. | EAEU KZ 7500361.01.01.08756 |
| CCC. | 2020322310003554 |

Programming

DIP switch configuration

Applicable devices can be configured via DIP switches. The DIP switches are located on the side of the device and can be adjusted with a small screwdriver or other implement.

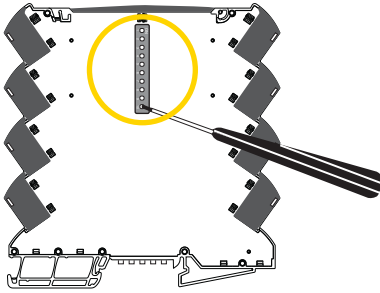

Remember to cycle power for power rail / terminals to reload DIP switch values at power up.

For easy DIP switch programming, our DIP switch configurator can be found at:
www.prelectronics.com/dip-switch-configurator/

Default factory settings

All DIP switches in the OFF position.

Input 0...20 mA
Output 0...20 mA

DIP switch settings

| | | | | | |
|--------------------------------|--|---------------------------------------|--|---------------------------------------|--|
| Input Current 0...20 mA | | Output channel 1 Current 0...20 mA | | Output channel 2 Current 0...20 mA | |
| Input Current 4...20 mA | | Output channel 1 Current 4...20 mA | | Output channel 2 Current 4...20 mA | |
| Input Voltage 0...10 V | | Output channel 1 Voltage 0...10 V | | Output channel 2 Voltage 0...10 V | |
| Input Voltage 2...10 V | | Output channel 1 Voltage 2...10 V | | Output channel 2 Voltage 2...10 V | |
| Input Voltage 0...5 V | | Output channel 1 Voltage 0...5 V | | Output channel 2 Voltage 0...5 V | |
| Input Voltage 1...5 V | | Output channel 1 Voltage 1...5 V | | Output channel 2 Voltage 1...5 V | |
| Input Tx (Active) 0...20 mA | | | | | |
| Input Tx (Active) 4...20 mA | | | | | |

Operation & troubleshooting

The 3000 series devices provide multiple features for easy user operation and for performing efficient troubleshooting. Monitoring the operational status is easy from the front LED(s).

Status indicator front LED



| Indicator pattern | Condition | Output and loop supply | Action required |
|-------------------|--|------------------------|-------------------------------------|
| OFF | No power supply or internal device failure | De-energized | Connect supply / replace device |
| ON / OFF | Power-up or restart | De-energized | - |
| 13 Hz, 15 ms | Normal operation | Energized | - |
| 1 Hz, 0.5 s | Restarting due to: Supply error / hardware. RAM or program flow error. | De-energized | Adjust supply / replace device |
| 1 Hz, 15 ms | Incorrect DIP switch setting | De-energized | Correct setting and re-power device |

Installation instructions

UL installation

Use 60/75°C copper conductors only.

| | |
|-------------------------|-----------|
| Wire size. | AWG 26-12 |
| UL file number. | E314307 |

The device is an Open Type Listed Process Control Equipment. To prevent injury resulting from accessibility to live parts the equipment must be installed in an enclosure. The Power Supply unit must comply with NEC Class 2, as described by the National Electrical Code® (ANSI / NFPA 70).

IECEX, ATEX and UKEX installation in Zone 2

| | |
|-------------------------------|------------------------|
| IECEX KEM 10.0068 X | Ex ec IIC T4 Gc |
| KEMA 10ATEX0147 X | II 3 G Ex ec IIC T4 Gc |
| DEKRA 21UKEX0055X | II 3 G Ex ec IIC T4 Gc |

For safe installation, the following must be observed. The device shall only be installed by qualified personnel who are familiar with the national and international laws, directives and standards that apply to this area.

The devices shall be installed in a suitable enclosure providing a degree of protection of at least IP54 according to EN IEC 60079-0, taking into account the environmental conditions under which the equipment will be used.

When the temperature under rated conditions exceeds 70°C at the cable or conduit entry point, or 80°C at the branching point of the conductors, the temperature specification of the selected cable shall be in compliance with the actual measured temperature.

To prevent ignition of the explosive atmospheres, disconnect power before servicing and do not separate connectors when energized and an explosive gas mixture is present.

For installation on power rail in Zone 2, only Power Rail type 9400 supplied by Power Control Unit type 9410 is allowed.

Do not mount or remove devices from the power rail when an explosive gas mixture is present.

cFMus installation in Division 2 or Zone 2

| | |
|-------------------------------------|---|
| FM17CA0003X / FM17US0004X | Class I, Div. 2, Group A, B, C, D T4 or Class I, Zone 2, AEx nA IIC T4 or Ex nA IIC T4 |
|-------------------------------------|---|

In class I, Division 2 or Zone 2 installations, the subject equipment shall be mounted within a tool-secured enclosure which is capable of accepting one or more of Class I, Division 2 wiring methods specified in the National Electrical Code (ANSI/NFPA 70) or in Canada in the Canadian Electrical Code (C22.1).

The 3000 System Isolators and Converters must be connected to limited output NEC Class 2 circuits, as outlined in the National Electrical Code® (ANSI / NFPA 70), only. If the devices are connected to a redundant power supply (two separate power supplies), both must meet this requirement.

Where installed in outdoor or potentially wet locations the enclosure shall at a minimum meet the requirements of IP54.

Warning: Substitution of components may impair suitability for zone 2 / division 2.

Warning: To prevent ignition of the explosive atmospheres, disconnect power before servicing and do not separate connectors when energised and an explosive gas mixture is present.

Warning: Do not mount or remove devices from the power rail when an explosive gas mixture is present.

Document history

The following list provides notes concerning revisions of this document.

| Rev. ID | Date | Notes |
|---------|------|---|
| 108 | 1745 | Models 31xx-N added. Specifications for max. required power and power dissipation added. PESO/CCOE approval added |
| 109 | 1939 | PESO/CCOE approval discontinued. Side label updated. |
| 110 | 2108 | CCC approval added. ATEX and IECEx approvals updated - Ex na changed to Ex ec. Side label updated. |
| 111 | 2205 | UKEX approval added. |
| 112 | 2448 | New EAC Ex certificate. |

We are near you, *all over the world*

Our trusted red boxes are supported wherever you are

All our devices are backed by expert service and a 5-year warranty. With each product you purchase, you receive personal technical support and guidance, day-to-day delivery, repair without charge within the warranty period and easily accessible documentation.

We are headquartered in Denmark, and have offices and authorized partners the world over. We are a local

business with a global reach. This means that we are always nearby and know your local markets well. We are committed to your satisfaction and provide PERFORMANCE MADE SMARTER all around the world.

For more information on our warranty program, or to meet with a sales representative in your region, visit prelectronics.com.

Benefit today from *PERFORMANCE MADE SMARTER*

PR electronics is the leading technology company specialized in making industrial process control safer, more reliable and more efficient. Since 1974, we have been dedicated to perfecting our core competence of innovating high precision technology with low power consumption. This dedication continues to set new standards for products communicating, monitoring and connecting our customers' process measurement points to their process control systems.

Our innovative, patented technologies are derived from our extensive R&D facilities and from having a great understanding of our customers' needs and processes. We are guided by principles of simplicity, focus, courage and excellence, enabling some of the world's greatest companies to achieve PERFORMANCE MADE SMARTER.