

PERFORMANCE
MADE
SMARTER

Product manual **5337**

2-wire transmitter with HART protocol



Segurança
INMETRO



TEMPERATURE | I.S. INTERFACES | COMMUNICATION INTERFACES | MULTIFUNCTIONAL | ISOLATION | DISPLAY

No. 5337V112-UK
From serial no.: 260923419

PR
electronics

6 Product Pillars

to meet your every need

Individually outstanding, unrivalled in combination

With our innovative, patented technologies, we make signal conditioning smarter and simpler. Our portfolio is composed of six product areas, where we offer a wide range of analog and digital devices covering over a thousand applications in industrial and factory automation. All our products comply with or surpass the highest industry standards, ensuring reliability in even the harshest of environments and have a 5-year warranty for greater peace of mind.



Temperature

Our range of temperature transmitters and sensors provides the highest level of signal integrity from the measurement point to your control system. You can convert industrial process temperature signals to analog, bus or digital communications using a highly reliable point-to-point solution with a fast response time, automatic self-calibration, sensor error detection, low drift, and top EMC performance in any environment.



I.S. Interface

We deliver the safest signals by validating our products against the toughest safety standards. Through our commitment to innovation, we have made pioneering achievements in developing I.S. interfaces with SIL 2 Full Assessment that are both efficient and cost-effective. Our comprehensive range of analog and digital intrinsically safe isolation barriers offers multifunctional inputs and outputs, making PR an easy-to-implement site standard. Our backplanes further simplify large installations and provide seamless integration to standard DCS systems.



Communication

We provide inexpensive, easy-to-use, future-ready communication interfaces that can access your PR installed base of products. All the interfaces are detachable, have a built-in display for readout of process values and diagnostics, and can be configured via push-buttons. Product specific functionality includes communication via Modbus and Bluetooth and remote access using our PR Process Supervisor (PPS) application, available for iOS and Android.



Multifunction

Our unique range of single devices covering multiple applications is easily deployable as your site standard. Having one variant that applies to a broad range of applications can reduce your installation time and training, and greatly simplify spare parts management at your facilities. Our devices are designed for long-term signal accuracy, low power consumption, immunity to electrical noise and simple programming.



Isolation

Our compact, fast, high-quality 6 mm isolators are based on microprocessor technology to provide exceptional performance and EMC-immunity for dedicated applications at a very low total cost of ownership. They can be stacked both vertically and horizontally with no air gap separation between units required.



Display

Our display range is characterized by its flexibility and stability. The devices meet nearly every demand for display readout of process signals and have universal input and power supply capabilities. They provide a real-time measurement of your process value no matter the industry and are engineered to provide a user-friendly and reliable relay of information, even in demanding environments.

2-wire transmitter with HART protocol 5337

Table of contents

Technical characteristics	4
Mounting / installation / programming	4
Applications	4
Order	5
Electrical specifications	5
Accessories	5
Changing the HART protocol version	8
Changing the HART protocol version using the PReset software and 5909 Loop Link or HART communication interface	8
Connections	11
Block diagram	12
Programming	12
Connection of transmitters in multidrop mode	14
Mechanical specifications	14
Mounting of sensor wires	14
ATEX Installation Drawing - 5337A	15
ATEX Installation Drawing - 5337D	17
IECEX Installation Drawing - 5337A	19
IECEX Installation Drawing - 5337D	21
CSA Installation Drawing - 5337A	23
CSA Installation Drawing - 5337D	24
FM Installation Drawing - 5337D	25
Desenho de instalação INMETRO - 5337A	27
Desenho de instalação INMETRO - 5337D	29
Document history	31

2-wire transmitter with HART protocol 5337

- RTD, TC, Ohm, or mV input
- 2 analog inputs and 5 device variables with status available
- HART protocol revision selectable from HART 5 or HART 7
- Hardware assessed for use in SIL applications
- Mounting on a DIN rail in safe area or hazardous gas and dust area

Application

- Linearised temperature measurement with TC and RTD sensors e.g. Pt100 and Ni100.
- HART communication and 4...20 mA analogue PV output for individual, difference or average temperature measurement of up to two RTD or TC input sensors.
- Conversion of linear resistance to a standard analogue current signal, e.g from valves or Ohmic level sensors.
- Amplification of bipolar mV signals to standard 4...20 mA current signals.
- Up to 63 transmitters (HART 7) can be connected in a multidrop communication setup.

Technical characteristics

- HART protocol revision can be changed by user configuration to either HART 5 or HART 7 protocol.
- The HART 7 protocol offers:
 - Long Tag numbers of up to 32 characters.
 - Enhanced Burst Mode and Event notification with time stamping.
 - Device variable and status mapping to any dynamic variable PV, SV, TV or QV.
 - Process signal trend measurement with logs and summary data.
 - Automatic event notification with time stamps.
 - Command aggregation for higher communication efficiency.
- The 5337 provides the required failure data (SFF and PFD_{AVG}) for SIL applications as per IEC 61508 / IEC 61511.
- Continuous check of vital stored data.
- Meeting the NAMUR NE 21 recommendations, the 5337 HART transmitter ensures top measurement performance in harsh EMC environments. Additionally, the 5337 meets NAMUR NE43 and NE89 recommendations.

Mounting / installation / programming

- For DIN form B sensor head or DIN rail mounting via the PR fitting type 8421.
- Configuration via standard HART communication interfaces or by PR 5909 Loop Link.

Applications

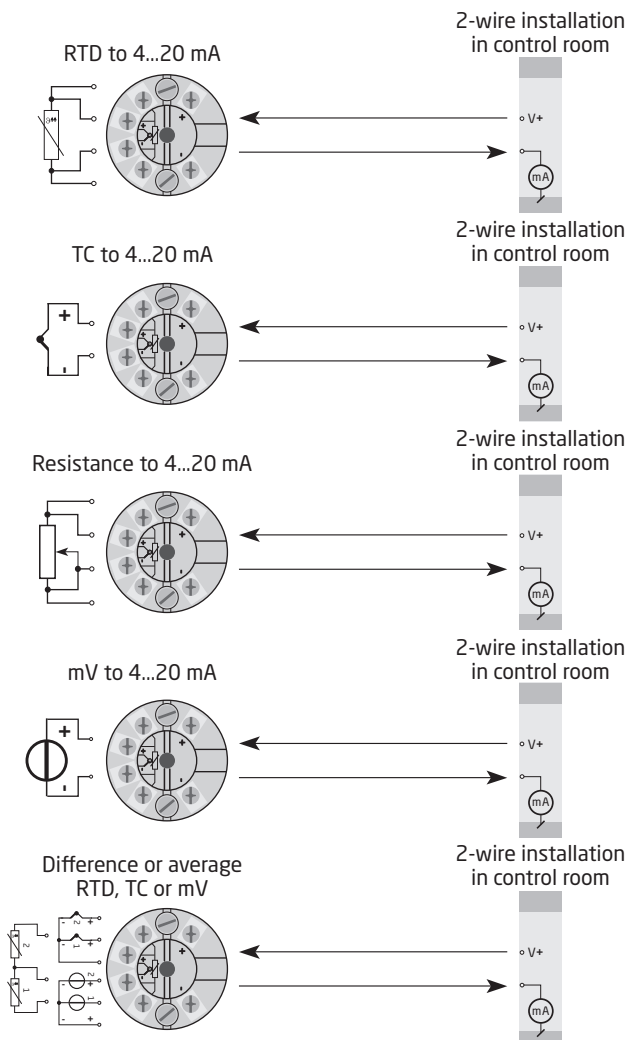

Order

Type	Version
5337	Zone 2 / Div. 2 : A
	Zone 0, 1, 2, 21, 22, M1 / DIV. 1, DIV. 2 : D

Accessories

5909 = Loop Link USB interface and PReset Software
8421 = DIN rail clip

Electrical specifications

Environmental conditions:

Specification range -40°C to +85°C
Calibration temperature. 20...28°
Humidity. < 95% RH (non-cond.)
Protection degree (encl./terminal) IP68 / IP00

Mechanical specifications:

Dimensions Ø 44 x 20.2 mm
Weight approx. 50 g
Max. wire size. 1 x1.5 mm² stranded wire
Screw terminal torque. 0.4 Nm
Vibration. IEC 60068-2-6
 2...25 Hz. ±1.6 mm
 25...100 Hz ±4 g

Common specifications:

Supply voltage, DC
 5337A. 8.0...35 VDC
 5337D. 8.0...30 VDC
Internal power dissipation
 5337A. 25 mW...0.8 W
 5337D. 25 mW...0.7 W
Voltage drop 8.0 VDC
Isolation voltage, test / operation. 1.5 kVAC / 50 VAC
Programming Loop Link & HART
Signal / noise ratio. > 60 dB
Response time (programmable) 1...60 s
Signal dynamics, input 22 bit
Signal dynamics, output 16 bit

Accuracy, the greater of general and basic values:

General values		
Input type	Absolute accuracy	Temperature coefficient
All	$\leq \pm 0.05\%$ of span	$\leq \pm 0.005\%$ of span / °C

Basic values		
Input type	Basic accuracy	Temperature coefficient
Pt50 - Pt1000	$\leq \pm 0.1^\circ\text{C}$	$\leq \pm 0.005^\circ\text{C}/^\circ\text{C}$
Ni50 - Ni1000	$\leq \pm 0.2^\circ\text{C}$	$\leq \pm 0.005^\circ\text{C}/^\circ\text{C}$
Lin. R	$\leq \pm 0.1 \Omega$	$\leq \pm 5 \text{ m}\Omega / ^\circ\text{C}$
Volt	$\leq \pm 10 \mu\text{V}$	$\leq \pm 0.5 \mu\text{V} / ^\circ\text{C}$
TC type: E, J, K, L, N, T, U	$\leq \pm 0.5^\circ\text{C}$	$\leq \pm 0.025^\circ\text{C} / ^\circ\text{C}$
TC type: B ¹ , Lr, R, S, W3, W5	$\leq \pm 1^\circ\text{C}$	$\leq \pm 0.1^\circ\text{C} / ^\circ\text{C}$
TC type: B ²	$\leq \pm 3^\circ\text{C}$	$\leq \pm 0.3^\circ\text{C} / ^\circ\text{C}$
TC type: B ³	$\leq \pm 8^\circ\text{C}$	$\leq \pm 0.8^\circ\text{C} / ^\circ\text{C}$
TC type: B ⁴	not specified	not specified

TC B¹ accuracy specification range > 400°C
 TC B² accuracy specification range > 160°C < 400°C
 TC B³ accuracy specification range > 85°C < 160°C
 TC B⁴ accuracy specification range < 85°C

TC cold junction compensation. < $\pm 1.0^\circ\text{C}$
 Max. offset on input signal 50% of selec. max. value

EMC - immunity influence.	< $\pm 0.1\%$ of span
Extended EMC immunity: NAMUR NE 21, A criterion, burst	< $\pm 1\%$ of span

Input specifications:

RTD input types:

RTD type	Min. value	Max. value	Min. span	Standard
Pt100	-200°C	+850°C	10°C	IEC 60751
Ni100	-60°C	+250°C	10°C	DIN 43760
Lin. R	0 Ω	7000 Ω	25 Ω	----

Pt50, Pt100, Pt200, Pt500, Pt1000, Ni50, Ni100, Ni120, Ni1000
 Cable resistance per wire (max.). 5 Ω
 (up to 50 Ω per wire is possible with reduced measurement accuracy)
 Sensor current Nom. 0.2 mA
 Effect of sensor cable resistance (3- / 4-wire) < 0.002 Ω/Ω

TC input types:

Type	Min. temperature	Max. temperature	Min. span	Standard
B	0°C	+1820°C	100°C	IEC584
E	-100°C	+1000°C	50°C	IEC584
J	-100°C	+1200°C	50°C	IEC584
K	-180°C	+1372°C	50°C	IEC584
L	-200°C	+900°C	50°C	DIN 43710
Lr	-200°C	+800°C	50°C	GOST 3044-84
N	-180°C	+1300°C	50°C	IEC584
R	-50°C	+1760°C	100°C	IEC584
S	-50°C	+1760°C	100°C	IEC584
T	-200°C	+400°C	50°C	IEC584
U	-200°C	+600°C	50°C	DIN 43710
W3	0°C	+2300°C	100°C	ASTM E988-90
W5	0°C	+2300°C	100°C	ASTM E988-90

Cold junction compensation (CJC):

Constant, internal or external via a Pt100 or Ni100 sensor

mV input:

Measurement range -800...+800 mV
 Min. span 2.5 mV
 Input resistance 10 MΩ

Output specifications and HART:

Signal range. 4...20 mA
 Min. signal range. 16 mA
 Updating time 440 ms
 Load resistance. $\leq (V_{\text{supply}} - 8) / 0.023 [\Omega]$
 Sensor error detection, programmable 3.5...23 mA
 (shorted sensor error detection is ignored at TC and mV input)
 NAMUR NE43 Upscale 23 mA
 NAMUR NE43 Downscale. 3.5 mA
 HART protocol revisions. HART 5 and HART 7

of span = of the presently selected range

Observed authority requirements:

EMC. 2014/30/EU
 ATEX 2014/34/EU
 RoHS. 2011/65/EU
 EAC TR-CU 020/2011
 EAC Ex TR-CU 012/2011

Approvals:

DNV, Ships & Offshore. TAA0000101

I.S. / Ex approvals:

5337A:
 ATEX DEKRA 20ATEX0109 X
 5337D:
 ATEX DEKRA 20ATEX0108 X
 FM FM17US0013X
 PESO. P658928/2
 5337A & 5337D:
 IECEx. DEK 20.0063X
 CSA 1125003
 INMETRO DEKRA 23.0011X
 EAC Ex. EAEU KZ 7500361.01.01.08756

Functional Safety:Hardware assessed for use in SIL applications. FMEDA report - www.prelectronics.com

Changing the HART protocol version

It is possible to change the unit's HART protocol revision by using the PReset software and a PR 5909 Loop Link interface or a HART interface.

Other HART configuration tools like a Handheld HART Terminal may also be used.

Procedure for using a HART hand-held terminal to change the 5337 from HART 7 to HART 5 and vice versa:

Change the 5337 from HART 7 to HART 5:

Drive the 5337 device **Online** and enter **Device setup - Diag/Service**.

Select **Write protection** and **Write protect** by entering "*****" (8 stars).

Select **New password** - type "*****" (8 stars) & then "HARTREV5".

Select **Write enable** by entering "-CHANGE-".

Change the 5335 (5337) from HART 5 to HART 7:

Drive the 5335 device **Online** and enter **Device setup - Diag/Service**.

Select **Write protection** and **Write protect** by entering "*****" (8 stars).

Select **New password** - type "*****" (8 stars) & then "HARTREV7".

Select **Write enable** and enter "-CHANGE-".

Please note this is only possible if the transmitter is marked "5337" on the label!

Changing the HART protocol version using the PReset software and 5909 Loop Link or HART communication interface

Switching from HART 7 to HART 5:

Select the 5337 product, click the "HART" tab and open the folder "Methods".

Click **Device Password / Write Protection / Protocol...** and select "Change protocol to HART 5" in the pop-up window, then acknowledge by pressing OK.

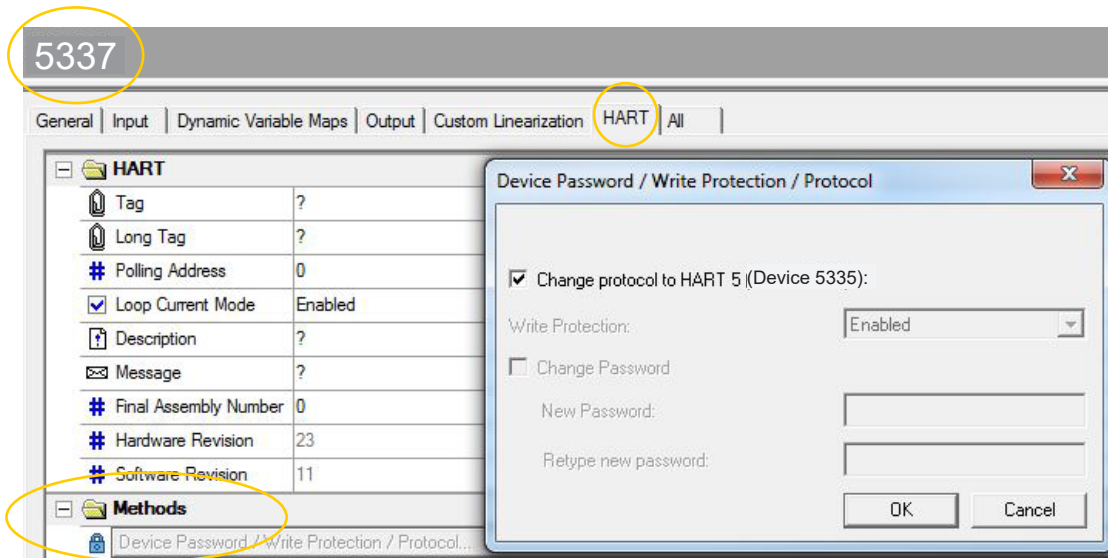

The following message will now appear:

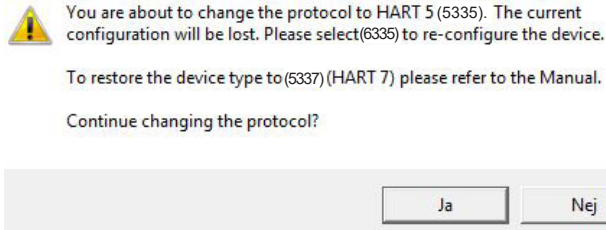

If you press "Ja" (Yes):

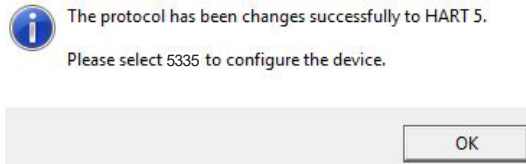

Switching from HART 5 to HART 7:

Please note this is only possible if the transmitter is marked "5337" on the label!

From PReset, select the 5335 product, click the "OPTIONS" tab click "Protect". Write protection must be set to "ON". Select **Change Password**. Type in the new password "HARTREV7" and Re-enter "HARTREV7". Click OK.

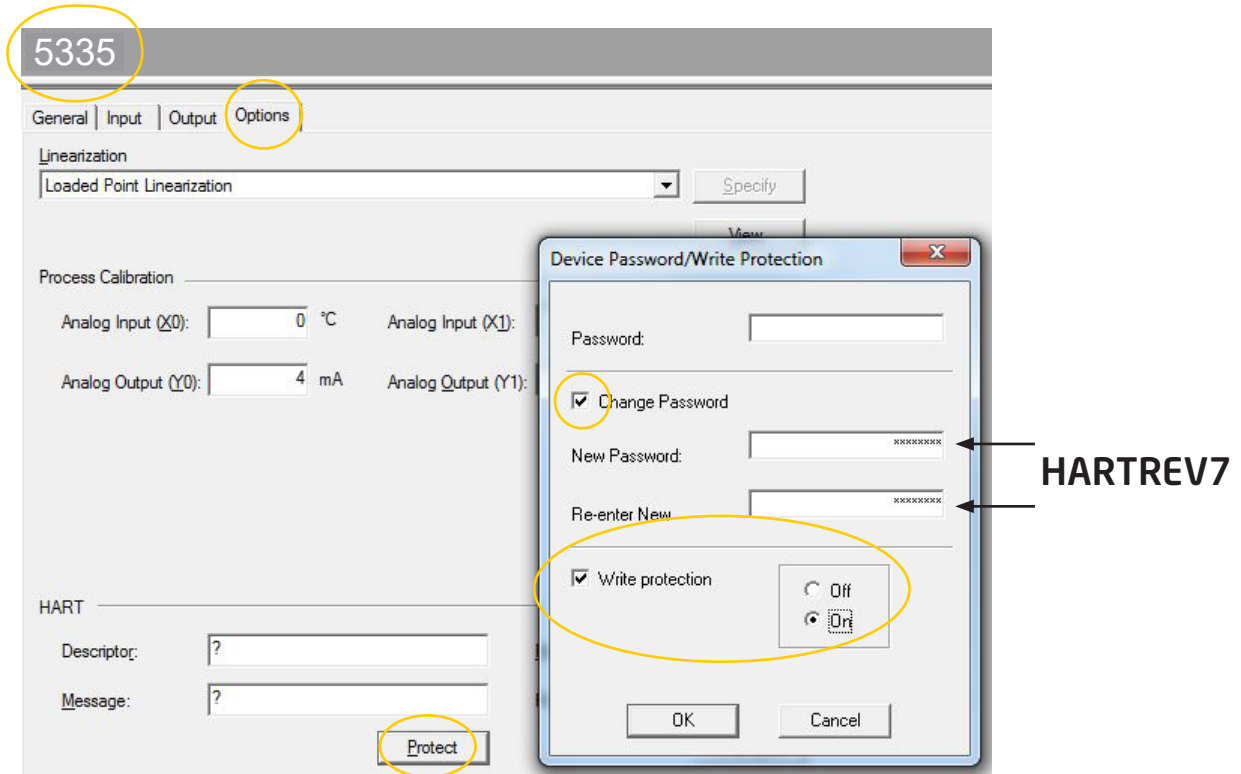

Switch **Write protection OFF** and write-enable the device by typing in the **Password "-CHANGE-"** in the top menu - acknowledge by pressing OK.

This action will reset the password to the default active password "*****" (8 stars) and restart the device in the updated HART 7 mode with write protection disabled. Now, select 5337 in PReset and reconfigure the device.

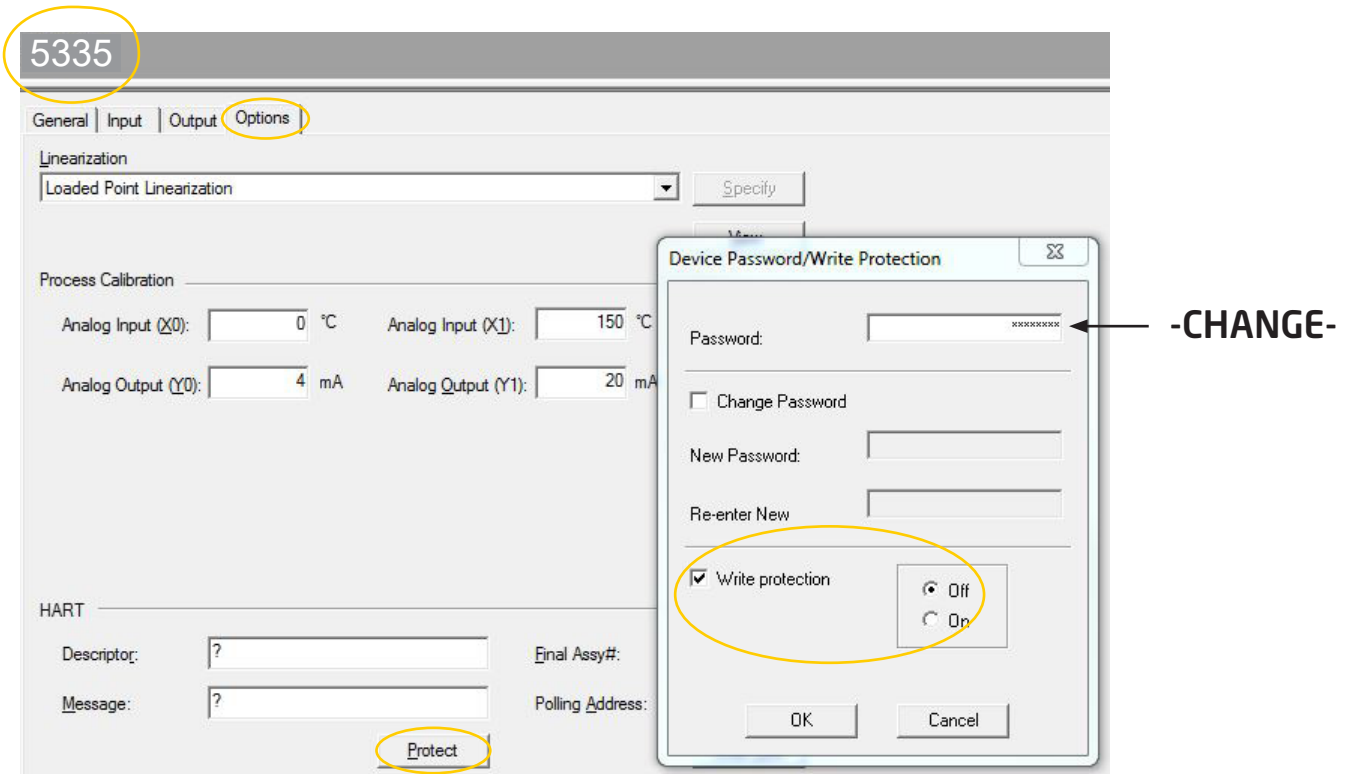

Connections

Input:

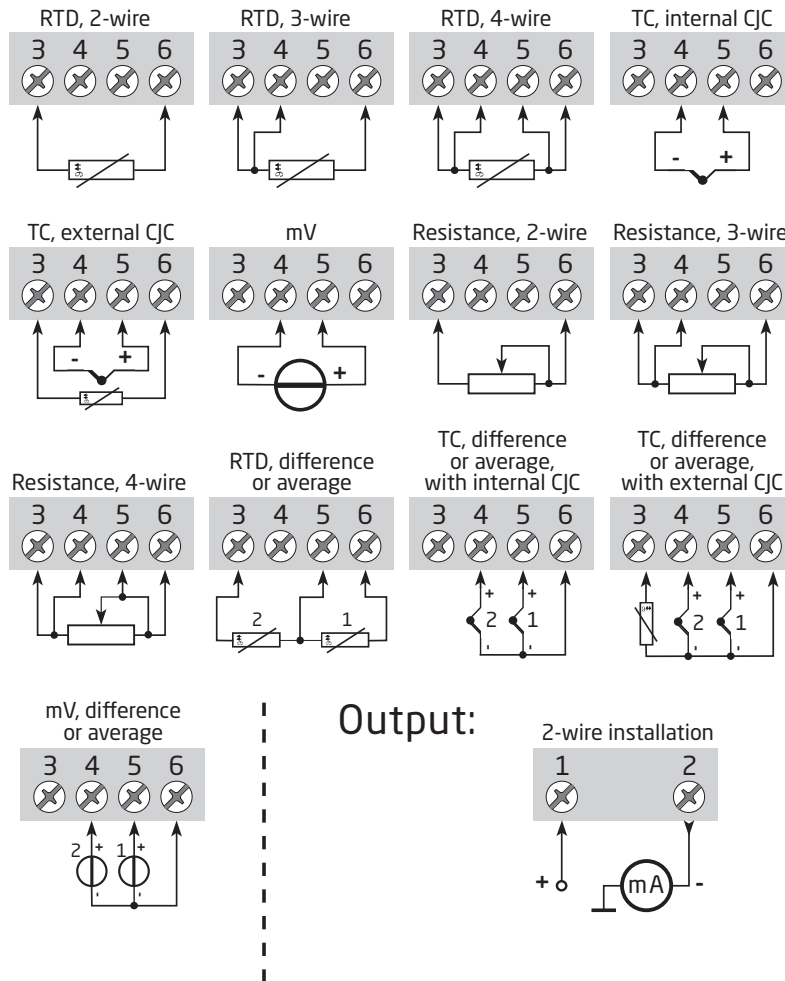

Block diagram

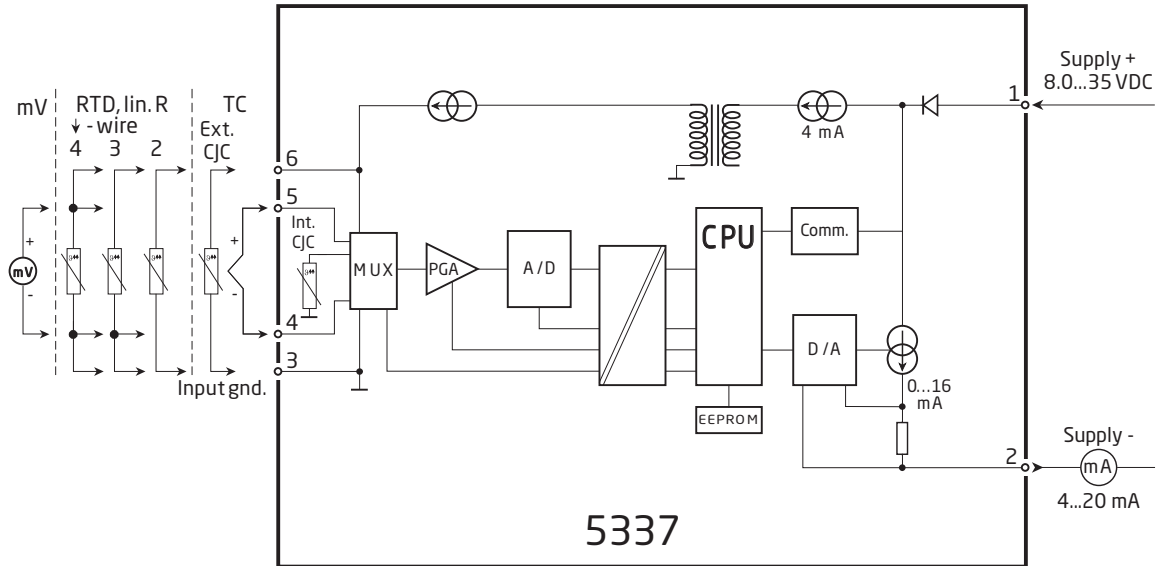

Programming

5337 can be configured in the following 3 ways:

1. With PR electronics A/S' communications interface Loop Link and PReset PC configuration software.
2. With a HART modem and PReset PC configuration software.
3. With a HART communicator with PR electronics A/S' DDL driver.

1: Loop Link

For programming please refer to the drawing below and the help functions in PReset.

Loop Link is not approved for communication with devices installed in hazardous (Ex) area.

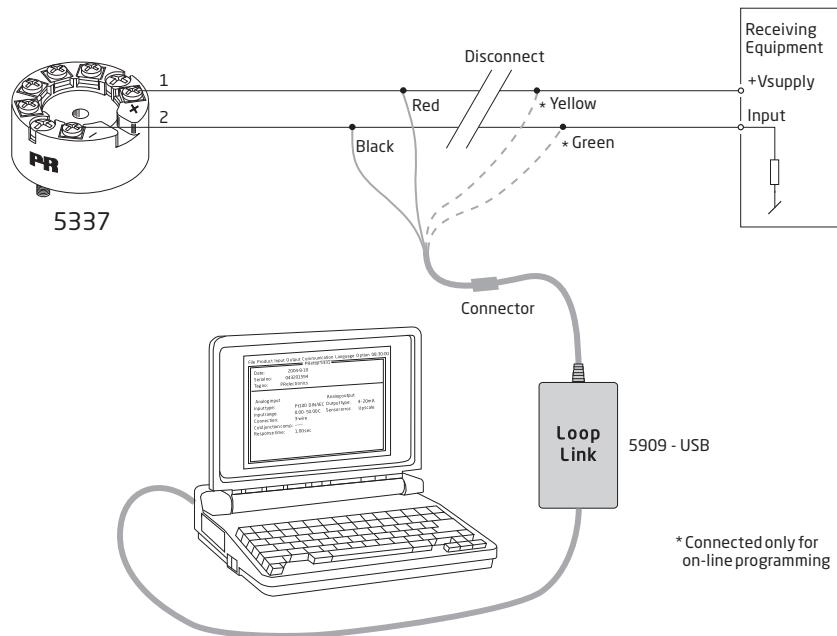

2: HART modem

For programming please refer to the drawing below and the help functions in PReset.

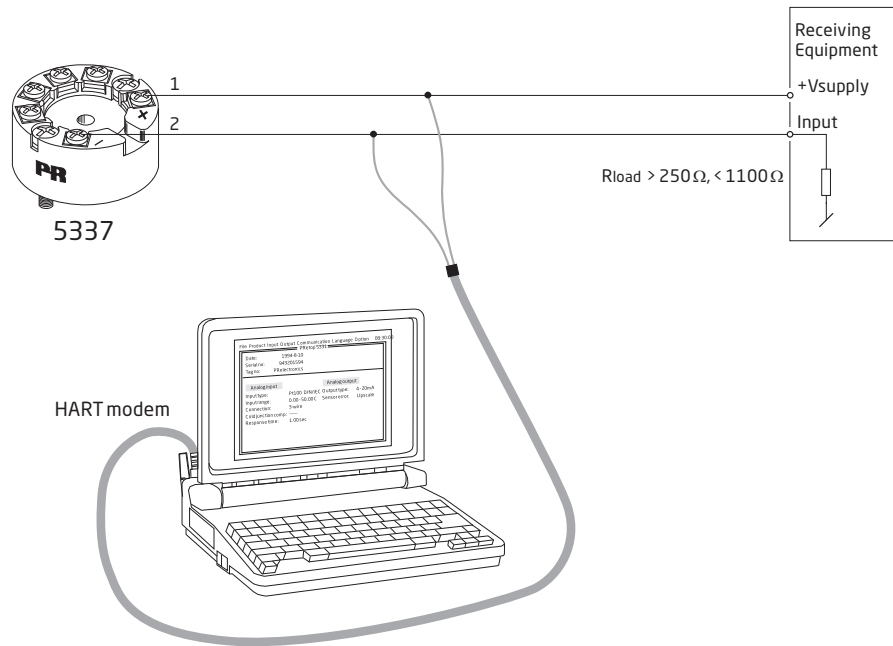

3: HART communicator

For programming please refer to the drawing below. To get access to productspecific commands, the HART communicator must be loaded with the PR electronics A/S DDL driver. This can be ordered either at the HART Communication Foundation or PR electronics A/S.

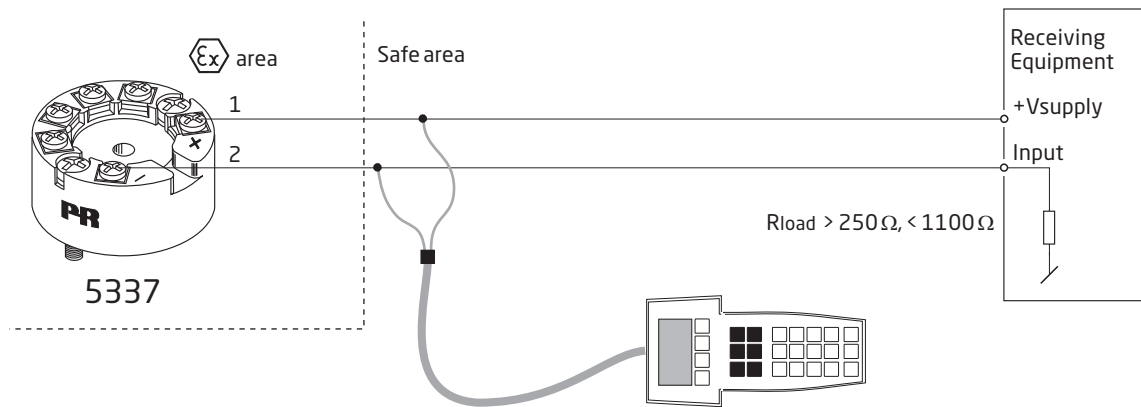

Connection of transmitters in multidrop mode

- The HART communicator or a PC modem can be connected across AB or BC.

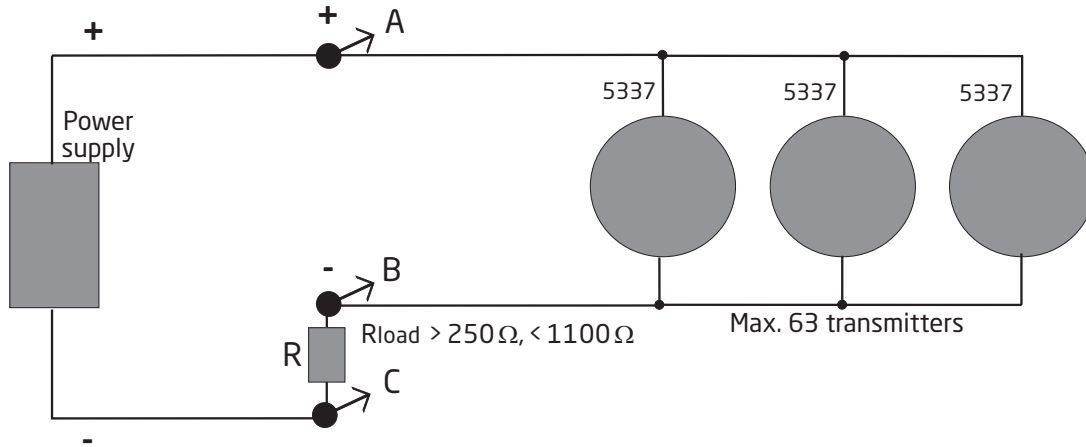

- The outputs of max. 63 transmitters can be connected in parallel for a digital HART communication on 2-wires.
- Before it is connected, each transmitter must be configured with a unique number from 1 to 63. If 2 transmitters are configured with the same number, both will be excluded. The transmitters must be programmed for multidrop mode (with a fixed output signal of 4 mA). Maximum current in the loop is therefore 252 mA.
- The communication is either by means of a HART communicator or a HART modem.
- The PReset PC configuration software can configure the individual transmitter for multidrop mode and provide it with a unique polling address.

Mechanical specifications

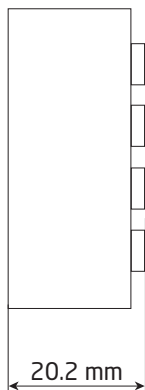
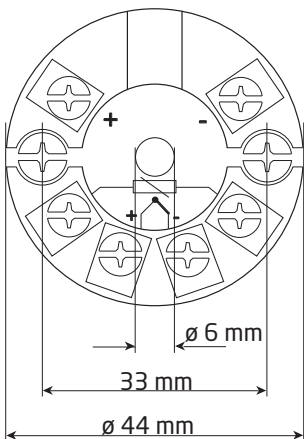

Mounting of sensor wires

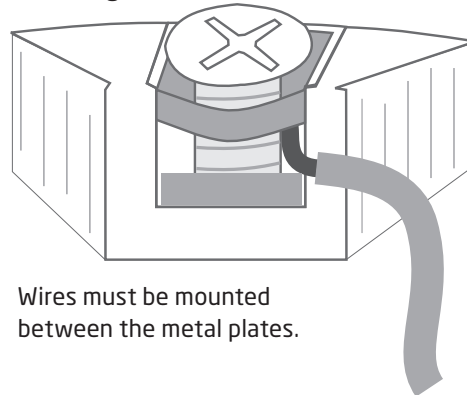

Wires must be mounted between the metal plates.

ATEX-installation drawing 5335QA02-V5R0

For safe installation of 5335A and 5337A the following must be observed. The module shall only be installed by qualified personnel who are familiar with the national and international laws, directives and standards that apply to this area. Year of manufacture can be taken from the first two digits in the serial number.

ATEX Certificate DEKRA 20ATEX0109 X

Marking



II 3 G Ex nA [ic] IIC T6 ... T4 Gc
 II 3 G Ex ec [ic] IIC T6 ... T4 Gc
 II 3 G Ex ic IIC T6 ... T4 Gc
 II 3 D Ex ic IIIC Dc

Standards

EN 60079-0: 2018, EN 60079-11: 2012,
 EN 60079-15: 2010, EN 60079-7:2015 +A1: 2018

Terminal 3,4,5,6	Terminal 1,2	Terminal 1,2	Terminal 1,2
Ex ic IIC, Ex ic IIIC	Ex ic IIC, Ex ic IIIC	Ex ic IIC, Ex ic IIIC	Ex nA, Ex ec
Uo: 9.6 V Io: 28 mA Po: 67 mW Lo: 35 mH Co: 3.5 μF	Ui = 35 V Ii = 110 mA Ci = 1 nF Li = 0 μH	Ui = 24 V Ii = 260 mA Ci = 1 nF Li = 0 μH	Umax ≤ 35 VDC or Umax ≤ 24 VDC

Ex ic IIC, Ex ic IIIC Temperature Class	Ambient temperature range	
	Ui=35 V	Ui=24 V
T6	-40°C to +54°C	-40°C to +63°C
T5	-40°C to +69°C	-40°C to +78°C
T4	-40°C to +85°C	-40°C to +85°C

Ex ec, Ex nA Temperature Class	Ambient temperature range	
	Vmax=35 V	Vmax=24 V
T6	-40°C to +43°C	-40°C to +55°C
T5	-40°C to +85°C	-40°C to +85°C
T4	-40°C to +85°C	-40°C to +85°C

Installation notes

If the enclosure is made of non-metallic plastic materials, electrostatic charges on the transmitter enclosure shall be avoided.

If the transmitter is installed in an explosive atmosphere requiring the use of equipment protection level Gc and applied in type of protection Ex ic, the transmitter shall be mounted in an enclosure that provides a degree of protection of at least IP20 according to EN 60259, and that is suitable for the application and correctly installed.

If the transmitter is installed in an explosive atmosphere requiring the use of equipment protection level Dc, the transmitter shall be mounted in a separately certified enclosure that provides a degree of protection of at least IP5X according to EN 60079-0, and that is suitable for the application and correctly installed. The surface temperature of the outer enclosure is +20 K above the ambient temperature, determined without a dust layer. Ambient temperature range: -40°C to +85°C.

If the transmitter is installed in an explosive atmosphere requiring the use of equipment protection level Gc and applied in type of protection Ex nA or Ex ec, the transmitter shall be mounted in a separately certified enclosure that provides a degree of protection of at least IP54 according to EN 60079-0, and that is suitable for the application and correctly installed.

If the transmitter is installed in an explosive atmosphere requiring the use of equipment protection level Gc and applied in type of protection Ex nA or Ex ec, the equipment shall only be used in an area of not more than pollution degree 2, as defined in EN 60664-1.

ATEX-installation drawing 5335QA01-V5R0



For safe installation of 5335D or 5337D the following must be observed. The module shall only be installed by qualified personnel who are familiar with the national and international laws, directives and standards that apply to this area. Year of manufacture can be taken from the first two digits in the serial number.

ATEX Certificate DEKRA 20ATEX0108 X

Marking



II 1 G Ex ia IIC T6...T4 Ga
II 2 D Ex ia IIIC Db
I M1 Ex ia I Ma

Standards EN IEC 60079-0: 2018, EN 60079-11: 2012

Hazardous area
Zone 0, 1, 2, 21, 22

Non Hazardous Area

Terminal: 3,4,5,6

Uo: 9.6 VDC
Io: 28 mA
Po: 67 mW
Lo: 35 mH
Co: 3.5 µF

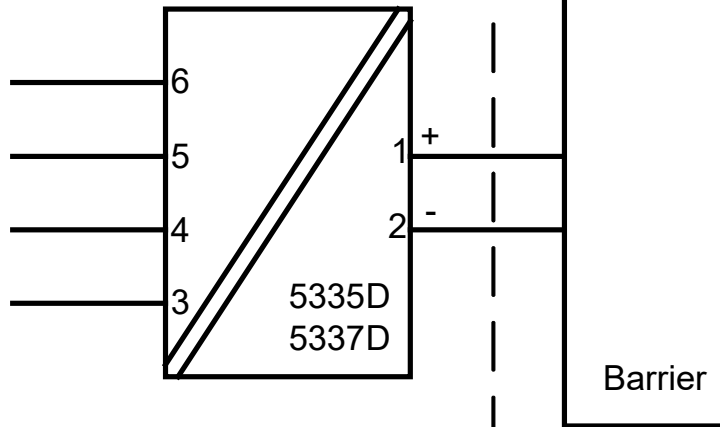

Terminal: 1,2

Ui: 30 VDC li: 120 mA Pi: 0.84 W or Pi: 0.75 W
Li: 0 µH Ci: 1.0 nF

Temperature Class	Ambient temperature range	
	Pi: 0.84 W	Pi: 0.75 W
T6	-40°C to +47°C	-40°C to +50°C
T5	-40°C to +62°C	-40°C to +65°C
T4	-40°C to +85°C	-40°C to +85°C

Installation notes

If the enclosure is made of non-metallic plastic materials, electrostatic charges on the transmitter enclosure shall be avoided.

If the transmitter is installed in an explosive atmosphere requiring the use of equipment protection level Ga, the transmitter shall be mounted in an enclosure that provides a degree of protection of at least IP20 according to EN 60529, and that is suitable for the application and correctly installed.

If the transmitter is installed in an explosive atmosphere requiring the use of equipment protection level Ga or Ma, and if the enclosure is made of aluminum, it must be installed such, that ignition sources due to impact and friction sparks are excluded.

If the transmitter is installed in an explosive atmosphere requiring the use of equipment protection level Db, the transmitter shall be mounted in a separately certified enclosure that provides a degree of protection of at least IP5X according to EN 60079-0, and that is suitable for the application and correctly installed. The surface temperature of the outer enclosure is +20 K above the ambient temperature, determined without a dust layer.
Ambient temperature range: -40°C to +85°C.

If the transmitter is installed in an explosive atmosphere requiring the use of equipment protection level Ma, the transmitter shall be mounted in an enclosure that provides a degree of protection of at least IP54 according to EN 60529, and that is suitable for the application and correctly installed.
Ambient temperature range: -40°C to +85°C.

Cable entries and blanking elements shall be used that are suitable for the application and correctly installed.

For an ambient temperature $\geq 60^{\circ}\text{C}$, heat resistant cables shall be used with a rating of at least 20 K above the ambient temperature.

The sensor circuit is not infallibly galvanically isolated from the input circuit. However, the galvanic isolation between the circuits is capable of withstanding a test voltage of 500 VAC for 1 minute.

IECEX-installation drawing 5335QI02-V5R0

For safe installation of 5335A and 5337A the following must be observed. The module shall only be installed by qualified personnel who are familiar with the national and international laws, directives and standards that apply to this area. Year of manufacture can be taken from the first two digits in the serial number.

Certificate	IECEX DEK 20.0063X
Marking	Ex nA [ic] IIC T6 ... T4 Gc Ex ec [ic] IIC T6 ... T4 Gc Ex ic IIC T6 ... T4 Gc Ex ic IIIC Dc
Standards	IEC 60079-0: 2017, IEC 60079-11: 2011, IEC 60079-15: 2010, IEC 60079-7:2017

Terminal 3,4,5,6	Terminal 1,2	Terminal 1,2	Terminal 1,2
Ex ic IIC, Ex ic IIIC	Ex ic IIC, Ex ic IIIC	Ex ic IIC, Ex ic IIIC	Ex nA, Ex ec
Uo: 9.6 V Io: 28 mA Po: 67 mW Lo: 35 mH Co: 3.5 µF	Ui = 35 V Ii = 110 mA Ci = 1 nF Li = 0 µH	Ui = 24 V Ii = 260 mA Ci = 1 nF Li = 0 µH	Umax ≤ 35 VDC or Umax ≤ 24 VDC

Ex ic IIC, Ex ic IIIC Temperature Class	Ambient temperature range	
	Ui=35 V	Ui=24 V
T6	-40°C to +54°C	-40°C to +63°C
T5	-40°C to +69°C	-40°C to +78°C
T4	-40°C to +85°C	-40°C to +85°C

Ex ec, Ex nA Temperature Class	Ambient temperature range	
	Vmax=35 V	Vmax=24 V
T6	-40°C to +43°C	-40°C to +55°C
T5	-40°C to +85°C	-40°C to +85°C
T4	-40°C to +85°C	-40°C to +85°C

Installation notes

If the enclosure is made of non-metallic plastic materials, electrostatic charges on the transmitter enclosure shall be avoided.

If the transmitter is installed in an explosive atmosphere requiring the use of equipment protection level Gc and applied in type of protection Ex ic, the transmitter shall be mounted in an enclosure that provides a degree of protection of at least IP20 according to IEC 60259, and that is suitable for the application and correctly installed.

If the transmitter is installed in an explosive atmosphere requiring the use of equipment protection level Dc, the transmitter shall be mounted in a separately certified enclosure that provides a degree of protection of at least IP5X according to IEC 60079-0, and that is suitable for the application and correctly installed. The surface temperature of the outer enclosure is +20 K above the ambient temperature, determined without a dust layer.
Ambient temperature range: -40°C to +85°C.

If the transmitter is installed in an explosive atmosphere requiring the use of equipment protection level Gc and applied in type of protection Ex nA or Ex ec, the transmitter shall be mounted in a separately certified enclosure that provides a degree of protection of at least IP54 according to IEC 60079-0, and that is suitable for the application and correctly installed.

If the transmitter is installed in an explosive atmosphere requiring the use of equipment protection level Gc and applied in type of protection Ex nA or Ex ec, the equipment shall only be used in an area of not more than pollution degree 2, as defined in IEC 60664-1.

IECEX-installation drawing 5335QI01-V5R0



For safe installation of 5335D or 5337D the following must be observed. The module shall only be installed by qualified personnel who are familiar with the national and international laws, directives and standards that apply to this area. Year of manufacture can be taken from the first two digits in the serial number.

Certificate	IECEX DEK 20.0063X
Marking	Ex ia IIC T6...T4 Ga Ex ia IIIC Db Ex ia I Ma
Standards	IEC 60079-0: 2017, IEC 60079-11: 2011

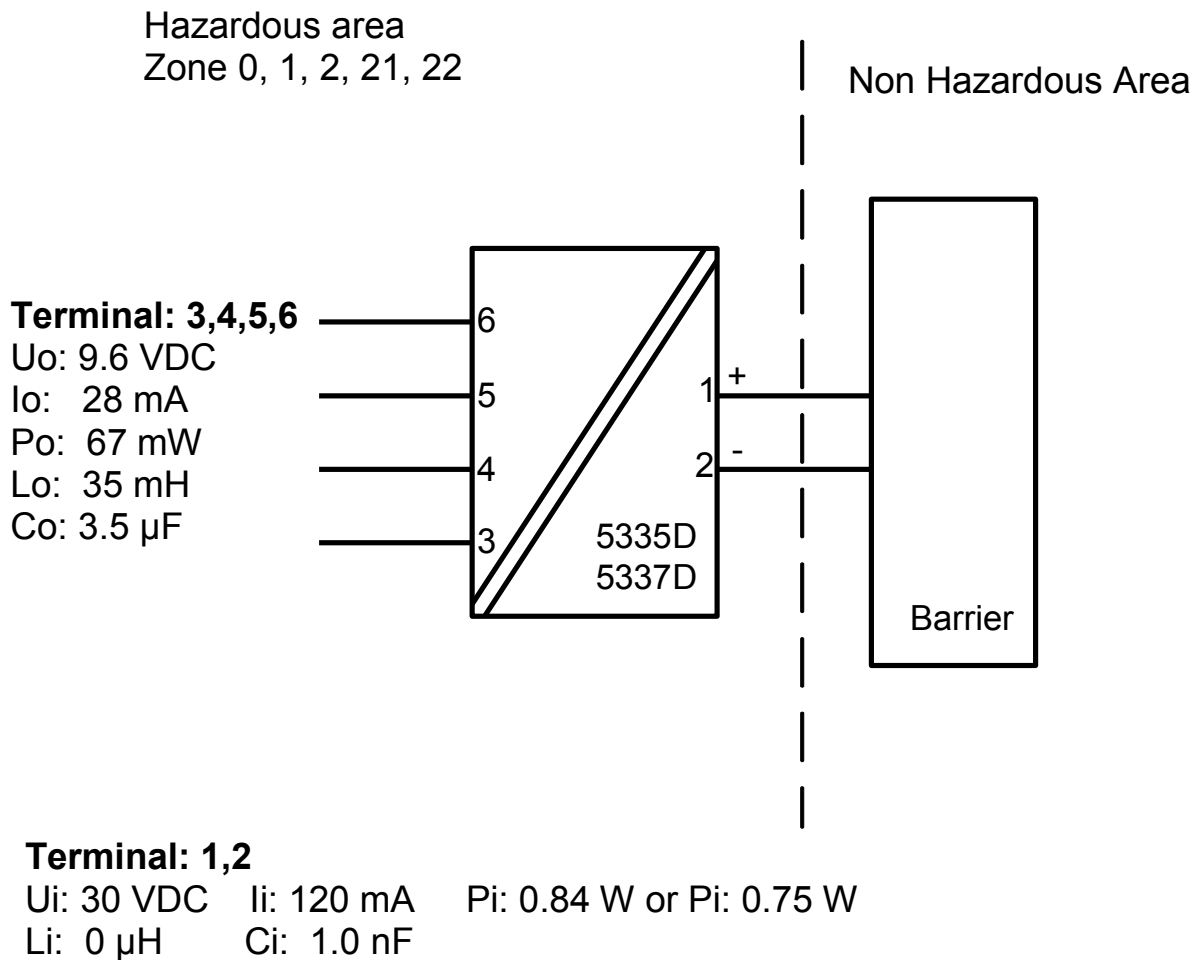

Temperature Class	Ambient temperature range	
	Pi: 0.84 W	Pi: 0.75 W
T6	-40°C to +47°C	-40°C to +50°C
T5	-40°C to +62°C	-40°C to +65°C
T4	-40°C to +85°C	-40°C to +85°C

Installation notes

If the enclosure is made of non-metallic plastic materials, electrostatic charges on the transmitter enclosure shall be avoided.

If the transmitter is installed in an explosive atmosphere requiring the use of equipment protection level Ga, the transmitter shall be mounted in an enclosure that provides a degree of protection of at least IP20 according to IEC 60529, and that is suitable for the application and correctly installed.

If the transmitter is installed in an explosive atmosphere requiring the use of equipment protection level Ga or Ma, and if the enclosure is made of aluminum, it must be installed such, that ignition sources due to impact and friction sparks are excluded.

If the transmitter is installed in an explosive atmosphere requiring the use of equipment protection level Db, the transmitter shall be mounted in a separately certified enclosure that provides a degree of protection of at least IP5X according to IEC 60079-0, and that is suitable for the application and correctly installed. The surface temperature of the outer enclosure is +20 K above the ambient temperature, determined without a dust layer.
Ambient temperature range: -40°C to +85°C.

If the transmitter is installed in an explosive atmosphere requiring the use of equipment protection level Ma, the transmitter shall be mounted in an enclosure that provides a degree of protection of at least IP54 according to IEC 60529, and that is suitable for the application and correctly installed.
Ambient temperature range: -40°C to +85°C.

Cable entries and blanking elements shall be used that are suitable for the application and correctly installed.

For an ambient temperature $\geq 60^\circ\text{C}$, heat resistant cables shall be used with a rating of at least 20 K above the ambient temperature.

The sensor circuit is not infallibly galvanically isolated from the input circuit. However, the galvanic isolation between the circuits is capable of withstanding a test voltage of 500 VAC for 1 minute.

For safe installation of the 5335A and 5337A the following must be observed. The module shall only be installed by qualified personnel who are familiar with the national and international laws, directives and standards that apply to this area.

Marking

Class I, Division 2, Group A,B,C,D T6...T4
 Ex nA[ic] IIC T6...T4
 Class I Zone 2 AEx nA[ic] IIC T6...T4

Hazardous Area
 CL I, Div 2, GP ABCD
 CL I, Zone 2, IIC

T4: -40°C to 85 °C
 T6: -40°C to 60 °C

Terminal:

3,4,5,6

Uo: 9.6 VDC
 Io: 28 mA
 Po: 67 mW
 Lo: 45 mH
 Co: 28 µF

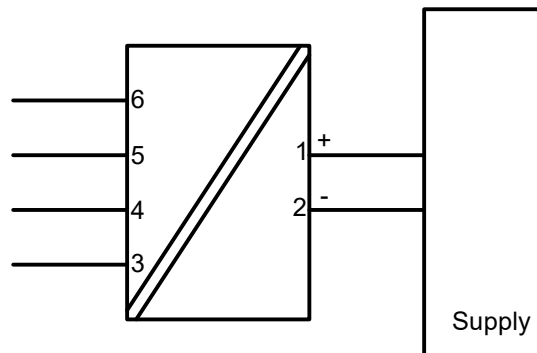

Terminal:

1-2

Functional Ratings:
 U nominal ≤ 35 VDC;
 I nominal ≤ 3.5 - 23 mA

NI Installation instructions

The transmitter must be installed in an enclosure providing a degree of protection of at least IP54 according to IEC60529 that is suitable for the application and is correctly installed. Cable entry devices and blanking elements shall fulfill the same requirements.

If the enclosure is made of non-metallic materials or of painted metal, electrostatic charging shall be avoided.

Use supply wires with a rating of at least 5 K above the ambient temperature.

Supply from a Class 2 Power Supply with Transient protection or equivalent.

WARNING: Substitution of components may impair suitability for Class I, Division 2

AVERTISSEMENT: la substitution de composants peut nuire à l'aptitude à la Classe I, Division 2.

WARNING: Do not disconnect equipment unless power has been switched off or the area is known to be safe.

AVERTISSEMENT: Ne débranchez pas l'équipement sauf si l'alimentation a été coupée ou si la zone est connue pour être sûre.

Non Incendive field wiring installation

The non incendive field Wiring Circuit concept allows interconnection of Nonincendive Field wiring Apparatus with Associated Nonincendive Field Wiring Apparatus or Associated Intrinsically Safe Apparatus or Associated Apparatus not specially examined in combination as a system using any of the wiring methods permitted for unclassified locations,

$V_{oc} < V_{max}$, $C_a \geq C_i + C_{cable}$, $L_a \geq L_i + L_{cable}$.

CSA Installation drawing 533XQC03

Hazardous area

T4: $-40 \leq T_a \leq 85^\circ\text{C}$
T6: $-40 \leq T_a \leq 60^\circ\text{C}$

Non Hazardous Area

Module 5331D and 5333D

Terminal: 3,4,5,6

Only passive, or non-energy storing devices such as RTD's and Thermocouples may be connected

Terminal: 1,2
Ui: 30 VDC
Ii: 120 mA
Pi: 0.84 W
Li: 10 μH
Ci: 1.0 nF

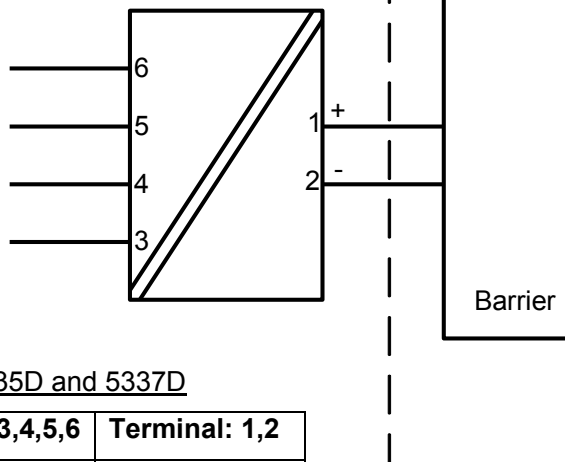

Module 5335D and 5337D

Terminal: 3,4,5,6	Terminal: 1,2
Uo: 9.6 VDC	Ui: 30 VDC
Io: 28 mA	Ii: 120 mA
Po: 67.2 mW	Pi: 0.84 W
Lo: 35 mH	Li: 0 μH
Co: 3.5 μF	Ci: 1.0 nF

CLASS 2258 04 - PROCESS CONTROL EQUIPMENT - Intrinsically Safe Entity - For Hazardous Locations

CLASS 2258 84 - PROCESS CONTROL EQUIPMENT - Intrinsically Safe Entity - For Hazardous Locations - Certified to US Standards

Class I, Division 1, Groups A, B, C and D T6...T4

Ex ia IIC T6...T4 Ga

Class I, Zone 0, AEx ia IIC Ga

Warning:

Substitution of components may impair intrinsic safety.

The transmitters must be installed in a suitable enclosure to meet installation codes stipulated in the Canadian Electrical Code (CEC) or for US the National Electrical Code (NEC).

FM Installation Drawing

Model 5331D, 5332D, 5333D and 5343B

Hazardous (Classified) Location

Class I, Division 1, Groups, A, B, C, D T4..T6
Class I, Zone 0, AEx ia IIC T4..T6

Ambient temperature limits
T4: -40 to + 85 deg. Celcius
T6: -40 to + 60 deg. Celcius

Terminal 1, 2
Vmax or Ui: 30 V
Imax or li: 120 mA
Pmax or Pi: 0.84 W
Ci: 1 nF
Li: 10 uH

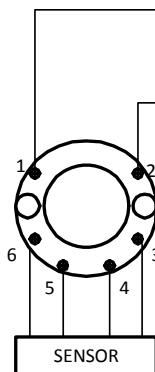

Non Hazardous Location

Associated Apparatus
or Barrier
with
entity Parameters:

$UM \leq 250V$
 $Voc \text{ or } Uo \leq Vmax \text{ or } Ui$
 $Isc \text{ or } Io \leq Imax \text{ or } li$
 $Po \leq Pi$
 $Ca \text{ or } Co \geq Ci + Ccable$
 $La \text{ or } Lo \geq Li + Lcable$

This device must not be connected
to any associated apparatus which
uses or generates more than 250
VRMS

Model 5335D, 5337D

Hazardous (Classified) Location

Class I, Division 1, Groups, A, B, C, D T4..T6
Class I, Zone 0, AEx ia IIC T4..T6

Ambient temperature limits
T4: -40 to + 85 deg. Celcius
T6: -40 to + 60 deg. Celcius

Terminal 1, 2
Vmax or Ui: 30 V
Imax or li: 120 mA
Pmax or Pi: 0.84 W
Ci: 1 nF
Li: 10 uH

Terminal 3, 4, 5, 6
Vt or Uo: 9.6 V
It or Io: 28 mA
Pt or Po: 67.2 mW
Ca or Co: 3.5 uF
La or Lo: 35 mH

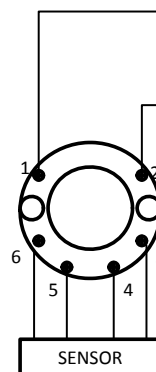

Non Hazardous Location

Associated Apparatus
or Barrier
with
entity Parameters:

$UM \leq 250V$
 $Voc \text{ or } Uo \leq Vmax \text{ or } Ui$
 $Isc \text{ or } Io \leq Imax \text{ or } li$
 $Po \leq Pi$
 $Ca \text{ or } Co \geq Ci + Ccable$
 $La \text{ or } Lo \geq Li + Lcable$

This device must not be connected
to any associated apparatus which
uses or generates more than 250
VRMS

The entity concept

The Transmitter must be installed according to National Electrical Code (ANSI-NFPA 70) and shall be installed with the enclosure, mounting, and spacing segregation requirement of the ultimate application.

Equipment that is FM-approved for intrinsic safety may be connected to barriers based on the ENTITY CONCEPT. This concept permits interconnection of approved transmitters, meters and other devices in combinations which have not been specifically examined by FM, provided that the agency's criteria are met. The combination is then intrinsically safe, if the entity concept is acceptable to the authority having jurisdiction over the installation.

The entity concept criteria are as follows:

The intrinsically safe devices, other than barriers, must not be a source of power.

The maximum voltage $U_i(V_{MAX})$ and current $I_i(I_{MAX})$, and maximum power $P_i(P_{max})$, which the device can receive and remain intrinsically safe, must be equal to or greater than the voltage (U_o or V_{OC} or V_t) and current (I_o or I_{SC} or I_t) and the power P_o which can be delivered by the barrier.

The sum of the maximum unprotected capacitance (C_i) for each intrinsically device and the interconnecting wiring must be less than the capacitance (C_a) which can be safely connected to the barrier.

The sum of the maximum unprotected inductance (L_i) for each intrinsically device and the interconnecting wiring must be less than the inductance (L_a) which can be safely connected to the barrier.

The entity parameters U_o, V_{OC} or V_t and I_o, I_{SC} or I_t , and C_a and L_a for barriers are provided by the barrier manufacturer.

NI Field Circuit Parameters

Model 5331D, 5332D, 5333D, 5335D, 5337D and 5343B

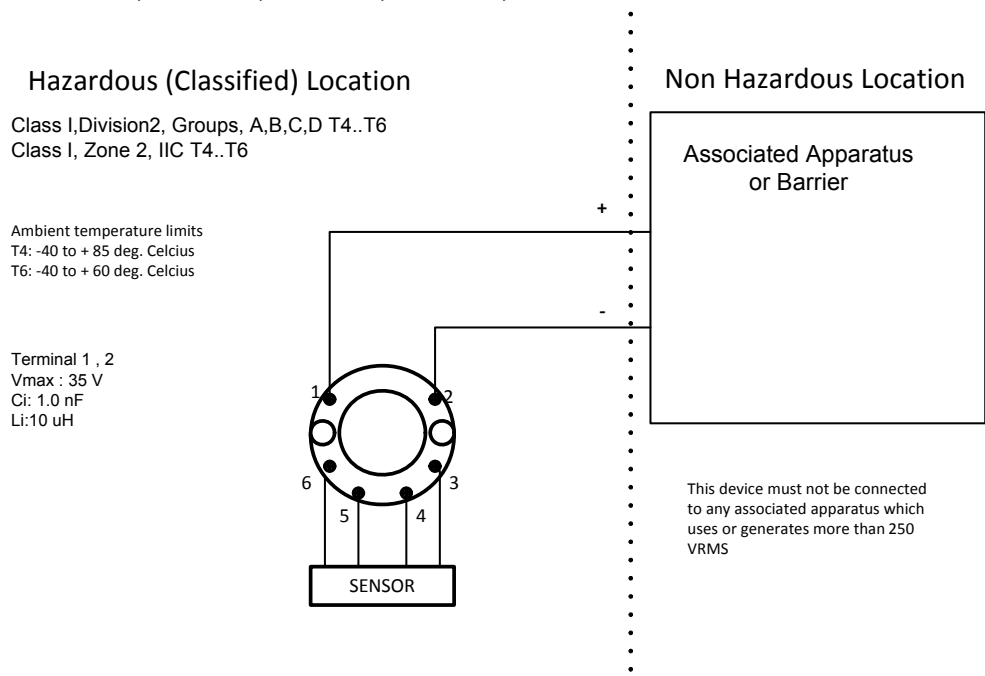

Desenho de Instalação INMETRO



Para instalação segura do 5335A ou 5337A o seguinte deve ser observado. O modelo deve apenas ser instalado por pessoas qualificadas que são familiarizadas com as leis nacionais e internacionais, diretrizes e padrões que se aplicam a esta área.
O ano de fabricação pode ser pego dos dois primeiros dígitos do número de série.

Certificado DEKRA 23.0011 X

Marcas
Ex ec [ic] IIC T6..T4 Gc
Ex ic IIC T6..T4 Gc
Ex ic IIIC Dc

Normas **ABNT NBR IEC 60079-0:2020 Versão Corrigida:2023**
ABNT NBR IEC 60079-11:2013 Versão Corrigida:2017

Terminais 3,4,5,6	Terminais 1,2	Terminais 1,2	Terminais 1,2
Ex ic IIC, Ex ic IIIC	Ex ic IIC, Ex ic IIIC	Ex ic IIC, Ex ic IIIC	Ex ec
Uo: 9,6 V Io: 28 mA Po: 67 mW Lo: 35 mH Co: 3,5 µF	Ui = 35 V Ii = 110 mA Ci = 1 nF Li = 10 µH	Ui = 24 V Ii = 260 mA Ci = 1 nF Li = 10 µH	Umax ≤ 35 Vdc or Umax ≤ 24 Vdc

Ex ic IIC, Ex ic IIIC Classe de temperatura	Faixa de temperatura ambiente	
	Ui=35V	Ui=24V
T6	-40 °C to +54 °C	-40 °C to +63 °C
T5	-40 °C to +69 °C	-40 °C to +78 °C
T4	-40 °C to +85 °C	-40 °C to +85 °C

Ex ec Classe de temperatura	Faixa de temperatura ambiente	
	Umax=35V	Umax=24V
T6	-40 °C to +43 °C	-40 °C to +55 °C
T5	-40 °C to +85 °C	-40 °C to +85 °C
T4	-40 °C to +85 °C	-40 °C to +85 °C

Notas de Instalação.

Se o invólucro for feito de materiais plásticos não metálicos, devem ser evitadas cargas eletrostáticas no invólucro do transmissor.

Se o transmissor for instalado em uma atmosfera explosiva que exija o uso de nível de proteção de equipamento Gc e aplicado no tipo de proteção Ex ic, o transmissor deverá ser montado em um gabinete que forneça um grau de proteção de pelo menos IP20 de acordo com ABNT NBR IEC 60529, e adequado à aplicação e instalado corretamente.

Se o transmissor for instalado em uma atmosfera explosiva que exija o uso de nível de proteção de equipamento Dc, o transmissor deverá ser montado em um invólucro certificado separadamente que forneça um grau de proteção de pelo menos IP5X de acordo com a ABNT NBR IEC 60079-0, e que seja adequado para o aplicativo e instalado corretamente. A temperatura da superfície do invólucro externo é +20 K acima da temperatura ambiente, determinada sem camada de poeira.
Faixa de temperatura ambiente: -40 °C a +85 °C

Se o transmissor for instalado em uma atmosfera explosiva que exija o uso de nível de proteção de equipamento Gc e aplicado no tipo de proteção Ex ec, o transmissor deverá ser montado em um invólucro certificado separadamente que forneça um grau de proteção de pelo menos IP54 de acordo com conforme ABNT NBR IEC 60079-0, e que seja adequado à aplicação e instalado corretamente.

Se o transmissor for instalado em uma atmosfera explosiva que exija o uso de nível de proteção de equipamento Gc e aplicado no tipo de proteção Ex oc, o equipamento deverá ser usado somente em uma área com grau de poluição não superior a 2, conforme definido na IEC 60664-1.

Desenho de Instalação INMETRO



Para instalação segura do 5335D ou 5337D o seguinte deve ser observado. O modelo deve apenas ser instalado por pessoas qualificadas que são familiarizadas com as leis nacionais e internacionais, diretrizes e padrões que se aplicam a esta área.
O ano de fabricação pode ser pego dos dois primeiros dígitos do número de série.

Certificado	DEKRA 23.0011 X
Marcas	Ex ia IIC T6...T4 Ga Ex ia IIIC Db Ex ia I Ma
Normas	ABNT NBR IEC 60079-0:2020 Versão Corrigida:2023 ABNT NBR IEC 60079-11:2013 Versão Corrigida:2017

Áreas classificadas
Zona 0, 1, 2, 21, 22

Áreas não
classificadas

Terminais:
3,4,5,6
Uo: 9,6 VDC
Io: 28 mA
Po: 67 mW
Lo: 35 mH
Co: 3,5 µF

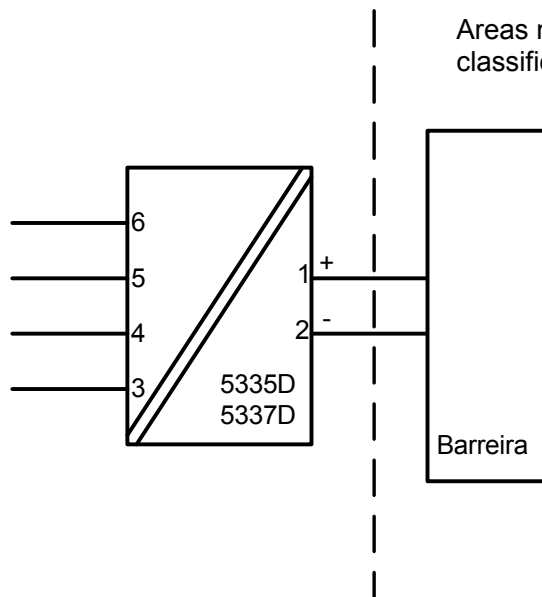

Terminais: 1,2
Ui: 30 VDC li: 120 mA Pi: 0,84 W or Pi: 0,75 W
Li: 10 µH Ci: 1,0nF

Classe de temperatura	Faixa de temperatura ambiente	
	Pi: 0,84W	Pi: 0,75W
T6	-40 °C to +47 °C	-40 °C to +50 °C
T5	-40 °C to +62 °C	-40 °C to +65 °C
T4	-40 °C to +85 °C	-40 °C to +85 °C

Notas de Instalação.

Se o invólucro for feito de materiais plásticos não metálicos, devem ser evitadas cargas eletrostáticas no invólucro do transmissor.

Se o transmissor for instalado em uma atmosfera explosiva que exija o uso de nível de proteção de equipamento Ga, o transmissor deverá ser montado em um invólucro que forneça um grau de proteção de pelo menos IP20 de acordo com a ABNT NBR IEC 60529, e que seja adequado para a aplicação e corretamente instalado.

Se o transmissor for instalado em uma atmosfera explosiva que exija o uso de equipamento de nível de proteção Ga ou Ma, e se o invólucro for feito de alumínio, ele deverá ser instalado de forma que fontes de ignição devido a faíscas de impacto e fricção sejam excluídas.

Se o transmissor for instalado em uma atmosfera explosiva que exija o uso de nível de proteção de equipamento Db, o transmissor deverá ser montado em um invólucro certificado separadamente que forneça um grau de proteção de pelo menos IP5X de acordo com a ABNT NBR IEC 60079-0, e que seja adequado para o aplicativo e instalado corretamente. A temperatura da superfície do invólucro externo é +20 K acima da temperatura ambiente, determinada sem camada de poeira. Faixa de temperatura ambiente: -40 °C a +85 °C

Se o transmissor for instalado em uma atmosfera explosiva que exija o uso de nível de proteção de equipamento Ma, o transmissor deverá ser montado em um invólucro que forneça um grau de proteção de pelo menos IP54 de acordo com a ABNT NBR IEC 60529, e que seja adequado para a aplicação e corretamente instalado. Faixa de temperatura ambiente: -40 °C a +85 °C

Devem ser utilizadas entradas de cabos e elementos de obturação adequados à aplicação e instalados corretamente.

Para uma temperatura ambiente $\geq 60^{\circ}\text{C}$, devem ser utilizados cabos resistentes ao calor com uma classificação de pelo menos 20 K acima da temperatura ambiente.

O circuito do sensor não é infalivelmente isolado galvânicamente do circuito de entrada. Porém, o isolamento galvânico entre os circuitos é capaz de suportar uma tensão de teste de 500Vac por 1 minuto.

Document history

The following list provides notes concerning revisions of this document.

Rev. ID	Date	Notes
104	1837	Specifications for internal power dissipation added. INMETRO certification changed to DEKRA. FM certificate number updated. FM installation drawing updated.
105	2006	CSA approval for 5337A received. Installation drawing added.
106	2139	ATEX and IECEx approvals updated - Ex na changed to Ex ec.
107	2202	CSA installation drawings updated.
108	2245	UKCA added.
109	2402	INMETRO approval updated - Ex nA replaced by Ex ec.
110	2450	New EAC Ex certificate.
111	2605	CSA installation drawing for 5337D updated. UKCA discontinued.
112	2624	PESO approval added.

We are near you, *all over the world*

Our trusted red boxes are supported wherever you are

All our devices are backed by expert service and a 5-year warranty. With each product you purchase, you receive personal technical support and guidance, day-to-day delivery, repair without charge within the warranty period and easily accessible documentation.

We are headquartered in Denmark, and have offices and authorized partners the world over. We are a local business

with a global reach. This means that we are always nearby and know your local markets well.

We are committed to your satisfaction and provide PERFORMANCE MADE SMARTER all around the world.

For more information on our warranty program, or to meet with a sales representative in your region, visit prelectronics.com.

Benefit today from *PERFORMANCE MADE SMARTER*

PR electronics is the leading technology company specialized in making industrial process control safer, more reliable and more efficient. Since 1974, we have been dedicated to perfecting our core competence of innovating high precision technology with low power consumption. This dedication continues to set new standards for products communicating, monitoring and connecting our customers' process measurement points to their process control systems.

Our innovative, patented technologies are derived from our extensive R&D facilities and from having a great understanding of our customers' needs and processes. We are guided by principles of simplicity, focus, courage and excellence, enabling some of the world's greatest companies to achieve PERFORMANCE MADE SMARTER.