



9420

Power Supply

Nr. 9420V100-UK

Product version: 9420-102



- DK** ▶ PR electronics A/S tilbyder et bredt program af analoge og digitale signalbehandlingsmoduler til industriel automation. Programmet består af Isolatorer, Displays, Ex-barrierer, Temperaturtransmittere, Universaltransmittere mfl. Vi har modulerne, du kan stole på i selv barske miljøer med elektrisk støj, vibrationer og temperaturudsving, og alle produkter opfylder de strengeste internationale standarder. Vores motto »Signals the Best« er indbegrebet af denne filosofi - og din garanti for kvalitet.
- UK** ▶ PR electronics A/S offers a wide range of analog and digital signal conditioning devices for industrial automation. The product range includes Isolators, Displays, Ex Interfaces, Temperature Transmitters, and Universal Devices. You can trust our products in the most extreme environments with electrical noise, vibrations and temperature fluctuations, and all products comply with the most exacting international standards. »Signals the Best« is the epitome of our philosophy - and your guarantee for quality.
- FR** ▶ PR electronics A/S offre une large gamme de produits pour le traitement des signaux analogiques et numériques dans tous les domaines industriels. La gamme de produits s'étend des transmetteurs de température aux afficheurs, des isolateurs aux interfaces SI, jusqu'aux modules universels. Vous pouvez compter sur nos produits même dans les conditions d'utilisation sévères, p.ex. bruit électrique, vibrations et fluctuations de température. Tous nos produits sont conformes aux normes internationales les plus strictes. Notre devise »SIGNALS the BEST« c'est notre ligne de conduite - et pour vous l'assurance de la meilleure qualité.
- DE** ▶ PR electronics A/S verfügt über ein breites Produktprogramm an analogen und digitalen Signalverarbeitungsgeräte für die industrielle Automatisierung. Dieses Programm umfasst Displays, Temperaturtransmitter, Ex- und galvanische Signaltrenner, und Universalgeräte. Sie können unsere Geräte auch unter extremen Einsatzbedingungen wie elektrisches Rauschen, Erschütterungen und Temperaturschwingungen vertrauen, und alle Produkte von PR electronics werden in Übereinstimmung mit den strengsten internationalen Normen produziert. »Signals the Best« ist Ihre Garantie für Qualität!

POWER SUPPLY

9420

CONTENTS

Warning.....	2
Description and construction.....	4
Installation.....	4
Assembly.....	4
Connecting cable	4
Input.....	4
Output.....	5
Signalling.....	5
Floating contacts	5
Active signal output.....	5
Signal loop.....	5
DC-OK LED	6
Parallel operation.....	6
Additional information for UL 508	7
ATEX additions of the operating instructions.....	7
Order	8
Electrical specifications for zone 2	8
Non Ex application	9
Ex / I.S. approval.....	9
Connections	10
Block diagram.....	11
Dimensions drawings.....	12
Mounting / demounting	12



**HAZARD-
OUS
VOLTAGE**

WARNING

Components with dangerously high voltage and high stored energy are located in the device. However, these are inaccessible. Failure to properly maintain the power supply can result in death, severe personal injury or substantial property damage. The power supplies may only be installed and put into operation by qualified personnel. The corresponding national regulations (e.g. UL, ANSI, VDE, DIN) must be observed. The successful and safe operation of this power supply is dependent on proper storage, handling, installation and operation.

Please observe the following points before putting the device into operation:

- Read operating instructions thoroughly.
- That the mains connection has been carried out by a competent person and protection against electrical shock is guaranteed!
- That the device can be disconnected outside the power supply in accordance with the regulations as in IEC/EN/UL 60950 or other national regulations.
- That the protective earth is connected.
- That the input wiring is sufficiently protected and dimensioned!
- That the output wiring is dimensioned according to the maximum output current or separately protected!
- Sufficient cooling is guaranteed!
- The temperature of the housing can become very high, depending on the ambient temperature and load.



CAUTION

Risk of electrical shock and electrical discharge. The power supply must not be opened until at least 5 minutes after complete disconnection of the mains.

Electrostatic sensitive device.

Qualified and trained personnel only may open the power supply.

FUSE

CAUTION

For continued protection against risk of fire replace with same type and rating of fuse! This fuse should be changed only by authorised and trained personnel because it is soldered on the board.

If the internal fuse is triggered, there is most probably an internal malfunction which must be inspected in the factory. Due to that return this device to your local distributor.



DANGER

Never work on power supplies if power is applied!

Attention: In case of non-observance or exceeding the mentioned limiting value of this manual, the function and electrical safety can be impaired and can destroy the power supply.

Before installation ensure that the main switch is switched off and prevented from being switched on again. In case of non-observance, touching of any live components or improper dealing with this power supply can result in death or fatal injury.

Description and construction

The 9420 power supply are built-in units. The mounting position has to fulfil the requirements for fireproof case according to UL60950, IEC/EN 60950 or other appropriate national standard. The relevant UL regulations or equivalent national regulations must be observed during installation.

The 9420 power supply is designed for mounting on a DIN rail (DIN EN 50022-35x15/7.5) and for operation from 115 or 230 VAC, 50/60 Hz (universal input voltage range, single-phase systems).

The output voltage of the 9420 power supply is potential-free (floating), protected against short circuit and open circuit conditions (see block diagram).

For use in a Pollution Degree 2 and overvoltage category 2.

Installation

A sufficiently strong DIN-rail has to be provided. The correct mounting position for optimal cooling performance must be observed. Above and below the power supply a minimum free space of 80 mm [3.15 in] is required and on each side of the power supply a minimum space of 50 mm [1.97 in] is required which allows air convection. The air temperature measured 10 mm [0.39 in] below the power supply must not exceed the specified values in the manual.

Assembly

To fix unit on the DIN-rail, hook top part of clip on DIN-rail, push down- (see Fig 2.1) and inwards (see Fig 2.2) until you hear a clipping sound.

To remove the unit, pull the latch of the clip with the aid of an insulated flat head screwdriver (see Fig 2.3). When clip has cleared bottom DIN rail remove the screwdriver from recess. Lift the unit off DIN-rail. See Fig 2.4.

Connecting cable

Only qualified personnel may carry out the installation. The devices are equipped with COMBICON plug connectors. This reliable and easy-to-assemble connection method enables a fast connection of devices and a visible isolation of the electrical connection if necessary.

Input

The 100-240 VAC connection is made by using pin no. 31, 32 and 33 and has to be carried out in accordance with the local regulations. Sufficiently dimensioned input wiring has to be ensured. A protective device (fuse, MCB, etc) and an easily accessible isolating device for disconnecting the power supply from mains must be provided. The protective earth conductor has to be connected. If flexible wires are used the wires have to be terminated. (e.g. by using ferrules).

Note: This unit contains an automatic input voltage selection switch. Do not change the input voltage from 110 / 115 VAC to 230 / 240 VAC without disconnecting the input supply line first.

Output

The 24VDC connection is made using the "+" and "-" connections. All output terminals should be connected to the load. Make sure that all output lines are dimensioned according to the maximum output current or are separately protected! The wires on the secondary side should have large cross sections in order to keep the voltage drops on these lines as low as possible.

To achieve a reliable and shockproof connection strip the connecting ends. If flexible wires are used the wires have to be terminated. (e.g. by using ferrules).

Signalling

The two DC-OK outputs are for enabling monitoring of the functions of the power supply. A floating signal contact and an active DC-OK signal are available. The DC-OK LED also enables a visual evaluation of the function of the power supply directly on site.

Floating contacts

The floating signal contacts opens and signals a drop in the output voltage between 18 and 22 VDC. Relay contacts are available on pin 16 and pin 17. Signals and ohmic loads with a voltage of up to 30 VDC and currents of up to 1A can be connected. For heavily inductive loads such as relay, a suitable protection circuit (e.g. damping diode) is necessary.

Active signal output

22 VDC \pm 2 VDC is applied on "DC-OK" - pin 15, 20 mA max. This signal output is referenced to -Vout (gnd.) and signals when the output voltage drops between 18 and 22 VDC.

The DC-OK signal is decoupled from the power output. It is thus not possible for parallel-switched devices to use the active output. The DC-OK signal can be directly connected to a logic input for evaluation.

Signal loop

The two above-mentioned signals can be easily combined.

Example: Monitoring of two devices.

Use the active signal output of device 1 and loop in the floating signal output of device 2. In the event of malfunctioning a common alarm is available. Up to 5 units can be looped in. This signal combination saves wiring costs and logic inputs.

DC-OK LED

The DC-OK LED is a two colour LED which indicates the status of the output and enables visual evaluation of the function locally in the control cabinet. DC-OK LED green - normal operation. DC-OK LED red - output failure if input mains is still present.

Parallel operation

Maximum 5 devices of the same type can be connected in parallel to enable increased output power. For n parallel connected devices the output current can be increased to $n \times I_{max}$. Parallel connection to increase efficiency is used for the expansion of existing systems. It is advisable to use parallel connection if the power supply does not cover the current requirement of the most powerful consumer. Otherwise the consumers should be spread among individual devices independent of one another.

To provide a proper and reliable start-up the jumper at connector J4 has to be set. If the jumper is set between pin 1 and pin 2 of connector J4 the unit is in normal mode. If the jumper is set between pin 2 and pin 3 on connector J4 the unit can be paralleled. At delivery this jumper is set for normal operation (between pin 1 and pin 2 of J4). To ensure symmetrical distribution of power, we recommend designing all cables from the power supply as busbar of the same length and with the same conductor cross section. The system makes it advisable to install a protective circuit at the output of each device when more than two power supplies are connected in parallel (e.g. decoupling diode or DC fuse). This prevents high reverse feed currents in the event of a secondary device fault.

Additional information for UL 508

The 9420 power supply are built-in units and must be installed in a cabinet with minimum dimensions of:

400 mm (width) x 500 mm (height) x 200 mm (depth)

ATEX additions of the operating instructions

To comply with the ATEX directive the following installation instructions have to be observed.

1. The 9420 Ex power supply unit shall be installed in switch cabinets or protective housings that meet the requirements of EN 60079-15 (housing protection type min. IP54).
2. The permissible ambient temperature range is -10°C to $+60^{\circ}\text{C}$.
3. For installation in switch cabinets or in protective housings, it must be ensured that the stipulated maximum temperatures (T_a) are not exceeded.
4. For assembling and maintenance the pluggable terminals must always be completely pushed in. In particular the snap-in locking devices at the pluggable terminals are to be examined for correct locking. Terminals with defective snap-in locking devices may not be used.

Order

9420 = Power supply

Electrical specifications for zone 2

Specifications range -10...+60°C

Storage temperature -20...+85°C

Common specifications:

Max. consumption..... 350 VA

Inrush current, max. (at 25°C, <2 ms) 25.0 AAC

Efficiency Typ. 88%

Fuse..... 4 A H / 250 VAC

Thermal overload protection..... Automatic restart

Isolation, input / output..... 4300 VDC

Temperature coefficient..... 0.02%/°C

Effect of supply voltage change

($V_{in\ min}$... $V_{in\ max}$)..... < 0,5%

Vibration, IEC 60068-2-6 1 g, 10...55 Hz, 3 axis sine sweep,

Vibration shock, IEC 60068-2-27 15 g, 3 axis half sine, 11ms

Wire size (min. / max.)..... 0.5...2.50 mm² / AWG 24...12
stranded wire

Screw terminal torque 0.5 Nm

Relative air humidity < 95% RH (non-cond.)

Dimensions (HxWxD)..... 110 x 54 x 114 mm

Protection degree..... IP20

Weight 700 g

Input:

Supply voltage (auto range)..... 187...264 VAC or
85...132 VAC

Frequency 50...60 Hz

Output:

Output voltage 24 VDC

Output power (max.) 120 W

Output current 5 A

Load stability (10%...max. load)..... < 0,5 %

Output ripple ($V_{in\ nom}$ and $I_{out\ max}$) ≤ 200 mV pk-pk

Non Ex application:

Operating temperature range

Max output.....	24 V / 180 W / 7 A
-10°C...40°C	100%
40°C...60°C.....	Load derating by 3.0 W / °C
60°C...70°C.....	Load derating by 4.0 W / °C

Ex / I.S. approval:

BUREAU VERITAS 08-002X	 II 3 G
	Ex nAC IIC T4
ATEX, applicable in.....	Zone 2
CSA, applicable in.....	Class I, Div. 2, Group A, B, C, D
	Class I, Zone 2, Ex nC IIC T4 U

Observed authority requirements:

EMC 2004/108/EC

Emission..... EN 61000-6-3, EN 61204-3

Immunity..... EN 61000-6-2, EN 61204-3

LVD 2006/95/EC..... EN 60950-1

ATEX 94/9/EF..... EN 60079-0, EN 60079-15,

CSA..... CSA 60950-1-03, UL 60950-1

UL, Standard for Safety..... UL 508

Standard:

CONNECTIONS

Input:

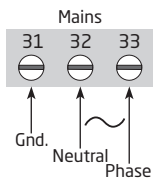

Outputs:

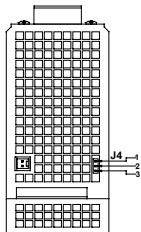
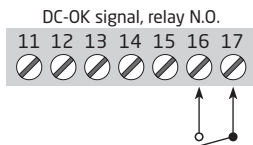
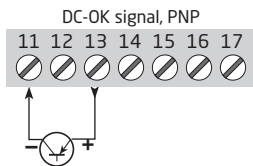
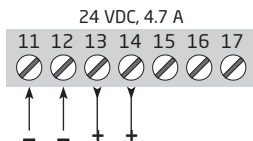

J4, Normal mode	 1 2 3
J4, Parallel mode	 1 2 3

BLOCK DIAGRAM

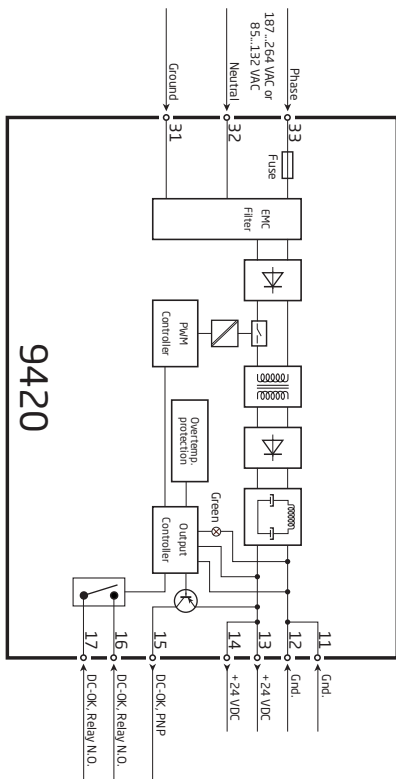

DIMENSIONS DRAWINGS

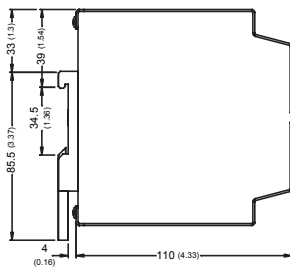
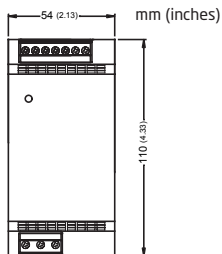

MOUNTING / DEMOUNTING

To fix the power supply on the DIN rail

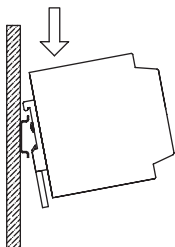

Fig. 2.1

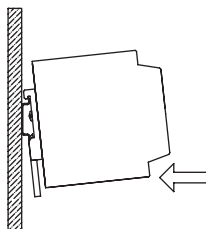

Fig. 2.2

To remove the power supply from the DIN rail

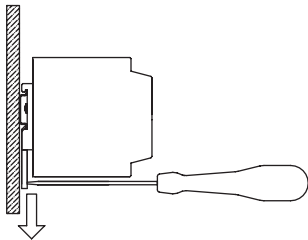

Fig. 2.3

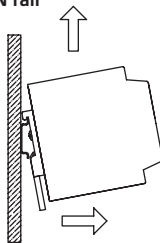

Fig. 2.4



Displays

Programmable displays with a wide selection of inputs and outputs for display of temperature, volume and weight, etc. Feature linearization, scaling, and difference measurement functions for programming via PReset software.



Ex interfaces

Interfaces for analog and digital signals as well as HART® signals between sensors / I/P converters / frequency signals and control systems in Ex zone 0, 1 & 2 and for some devices in zone 20, 21 & 22.



Isolation

Galvanic isolators for analog and digital signals as well as HART® signals. A wide product range with both loop-powered and universal isolators featuring linearization, inversion, and scaling of output signals.



Temperature

























A wide selection of transmitters for DIN form B mounting and DIN rail devices with analog and digital bus communication ranging from application-specific to universal transmitters.



Universal

PC or front programmable devices with universal options for input, output and supply. This range offers a number of advanced features such as process calibration, linearization and auto-diagnosis.



- 
 www.preelectronics.fr
 sales-fr@preelectronics.com
- 
 www.preelectronics.de
 sales-de@preelectronics.com
- 
 www.preelectronics.es
 sales-es@preelectronics.com
- 
 www.preelectronics.it
 sales-it@preelectronics.com
- 
 www.preelectronics.se
 sales-se@preelectronics.com
- 
 www.preelectronics.co.uk
 sales-uk@preelectronics.com
- 
 www.preelectronics.com
 sales-us@preelectronics.com
- 
 www.preelectronics.cn
 sales-cn@preelectronics.com

Head office

Denmark
 PR electronics A/S
 Lerbakken 10
 DK-8410 Rønde

www.preelectronics.com
sales-dk@preelectronics.com
 tel. +45 86 37 26 77
 fax +45 86 37 30 85



QUALITY SYSTEM AND ENVIRONMENTAL MANAGEMENT SYSTEM
 DS/EN ISO 9001
 DS/EN ISO 14001

